

Name: _____

Edexcel_Materials

Questions

Date:

Time:

Total marks available:

Total marks achieved: _____

Questions

Three springs X, Y and Z have forces applied to them. For each spring a graph is plotted of length L of the spring against force F . The graphs are shown below:

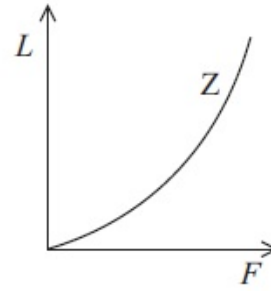
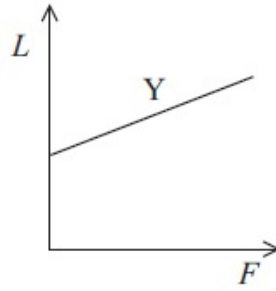
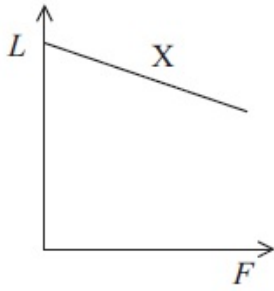

Which of the springs obey Hooke's law?

- A** X and Y
- B** X and Z
- C** Y and Z
- D** Y only

(Total for question = 1 marks)

Q2.

A spring obeys Hooke's law. A force of 2.0 N extends the spring by 0.30 m.

A 6.0 N force will extend the spring by

- A** 0.10 m
- B** 0.30 m
- C** 0.60 m
- D** 0.90 m

(Total for question = 1 mark)

Q3. A spring is suspended from a bar. When a load of 6.0 N is added to the bottom of the spring, its length changes from 0.040 m to 0.13 m.

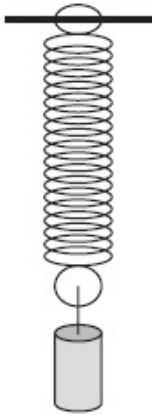

To find the spring constant of the spring you would use

$$\frac{6.0 \text{ N}}{0.090 \text{ m}} \quad \mathbf{A} \quad \frac{0.13 \text{ m}}{6.0 \text{ N}}$$

$$\frac{6.0 \text{ N}}{0.090 \text{ m}} \quad \mathbf{B} \quad \frac{6.0 \text{ N}}{0.13 \text{ m}}$$

$$\frac{6.0 \text{ N}}{0.090 \text{ m}} \quad \mathbf{C} \quad \frac{6.0 \text{ N}}{0.090 \text{ m}}$$

$$\frac{6.0 \text{ N}}{0.090 \text{ m}} \quad \mathbf{D} \quad \frac{0.090 \text{ m}}{6.0 \text{ N}}$$

(Total for Question = 1 mark)

Q4.

In a physics lesson the following graphs are given to the students. The graphs show the relationship between force and extension for samples of two different materials, A and B.

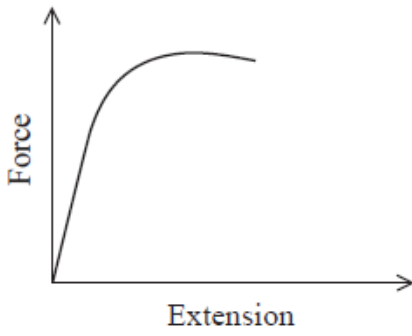

Sample A

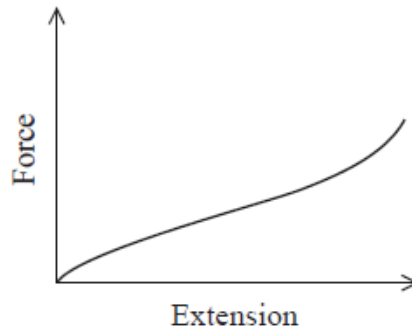

Sample B

A student states that sample A obeys Hooke's law for small extensions and sample B does not. Use the graphs to explain the validity of the student's statement.

(3)

.....

.....

.....

.....

.....

.....

.....

(Total for question = 3 marks)

Q5.

Answer the question with a cross in the box you think is correct (☒). If you change your mind about an answer, put a line through the box (☒) and then mark your new answer with a cross (☒).

A deforming force is applied to a sample of material.

Which row of the table shows the axes of a graph for which the gradient is stiffness k ?

	y-axis	x-axis
<input type="checkbox"/> A	extension	force
<input type="checkbox"/> B	force	length
<input type="checkbox"/> C	stress	strain
<input type="checkbox"/> D	strain	length

(Total for question = 1 mark)

Q6.

Two identical springs are arranged side by side as shown.

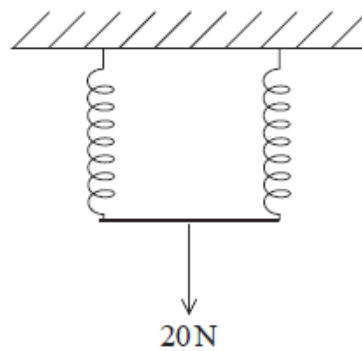

When a force of 20 N is applied, an extension of 8 cm is obtained.

A force of 5 N is applied to one of the springs on its own.

Which of the following is the extension obtained?

(1)

- A 2 cm
- B 4 cm
- C 8 cm
- D 16 cm

(Total for question = 1 mark)

Q7.

The diagram shows a force-extension graph for a wire.

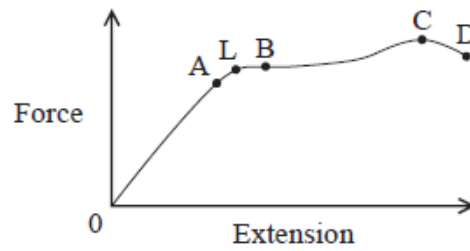

L is the elastic limit.

Which point represents the yield point?

(1)

- A
- B
- C
- D

(Total for question = 1 mark)

Q8.

A cylinder of length 50 cm has a force applied to it. The new length of the cylinder is 45 cm.

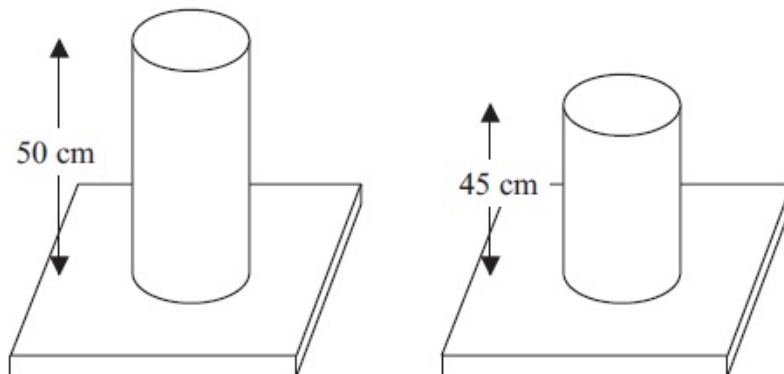

The quantity determined using is $\frac{5 \text{ cm}}{50 \text{ cm}}$ is

A compressive strain.
@TOPhysicsTutor

- B** compressive stress.
- C** tensile strain.
- D** tensile stress.

(Total for question = 1 marks)

Q9.

A spring with a spring constant 140 Nm^{-1} is extended. The elastic potential energy stored is 1.6 J

The extension of the wire is found using

- A** $\frac{1.6}{140}$
- B** $\frac{2 \times 1.6}{140}$
- C** $\sqrt{\frac{1.6}{140}}$
- D** $\sqrt{\frac{2 \times 1.6}{140}}$

(Total for question = 1 mark)

Q10.

Answer the question with a cross in the box you think is correct (☒). If you change your mind about an answer, put a line through the box (~~☒~~) and then mark your new answer with a cross (☒).

The Young Modulus of a material can be expressed by the formula $E = \frac{Fx}{A\Delta x}$.

The derivation of this formula is

$$E = \frac{\sigma}{\epsilon}$$

So $E = \dots\dots\dots$

And $E = \frac{Fx}{A\Delta x}$

Which of the following completes the second line of the derivation?

A $\frac{\frac{x}{\Delta x}}{\frac{F}{A}}$

B $\frac{\frac{\Delta x}{x}}{\frac{F}{A}}$

C $\frac{\frac{F}{A}}{\frac{\Delta x}{x}}$

D $\frac{\frac{F}{A}}{\frac{x}{\Delta x}}$

(Total for question = 1 mark)

Q11. A steel wire and a brass wire, with identical cross sectional areas and lengths, are fused together. The Young modulus for steel is approximately twice that of brass.

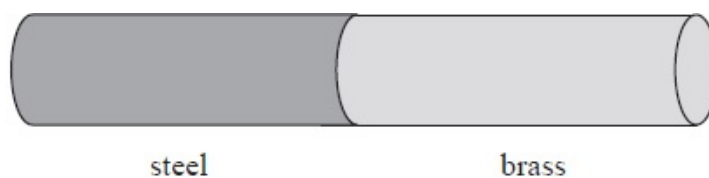

The combined wire is stretched.

The ratio $\frac{\text{extension of steel wire}}{\text{extension of brass wire}}$ is approximately

A 2.0

B 1.0

C 0.50

 D 0.25**(Total for Question = 1 mark)**

Q12.

A student investigated the behaviour of a spring under tension. The spring was hung vertically with a mass holder attached.

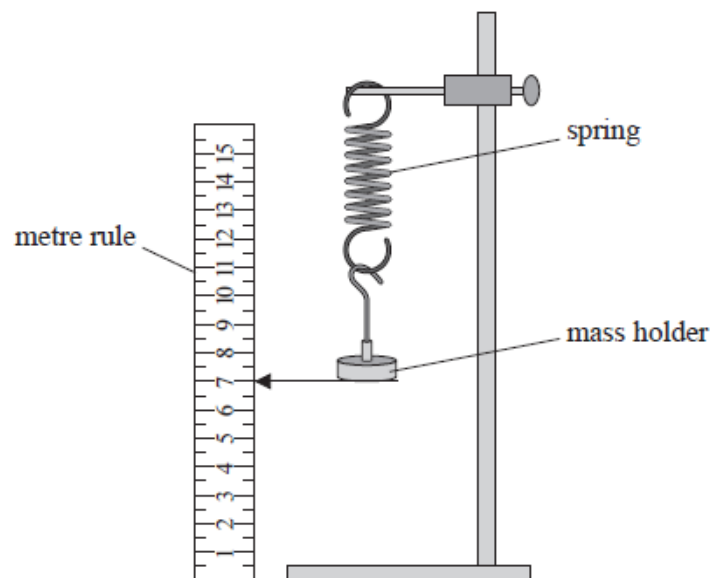

The position of the bottom of the mass holder was recorded. The spring was stretched by adding masses to the mass holder and the new positions were recorded. The extension of the spring each time was calculated.

The student produced the following table.

Mass added / g	Extension / cm	Stretching force / N
50	1.9	0.49
70	3	0.69
90	3.5	0.9
110	4.5	1.08
130	5.3	1.28
150	5.8	1.47

The student used her data to plot a graph as shown.

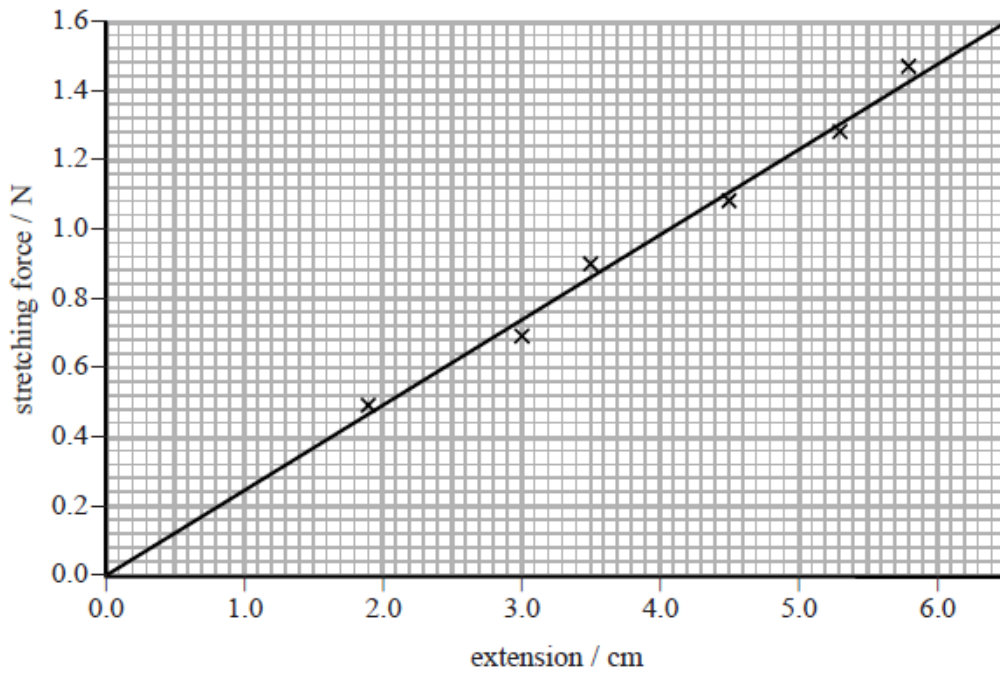

Determine a value for the force constant k of the spring.

(2)

.....

.....

.....

.....

.....

.....

.....

.....

.....

.....

$k =$

(Total for question = 2 marks)

Q13.

A student is investigating the extension of a spring.

A force of 29 N is applied to the spring and it extends by 32 cm. The spring obeys Hooke's law.

Calculate the extension of the spring when a force of 27 N is applied.

(2)

.....

.....

.....

.....

Extension =

(Total for question = 2 marks)

Q14.

A student investigated the behaviour of a spring under tension. The spring was hung vertically with a mass holder attached.

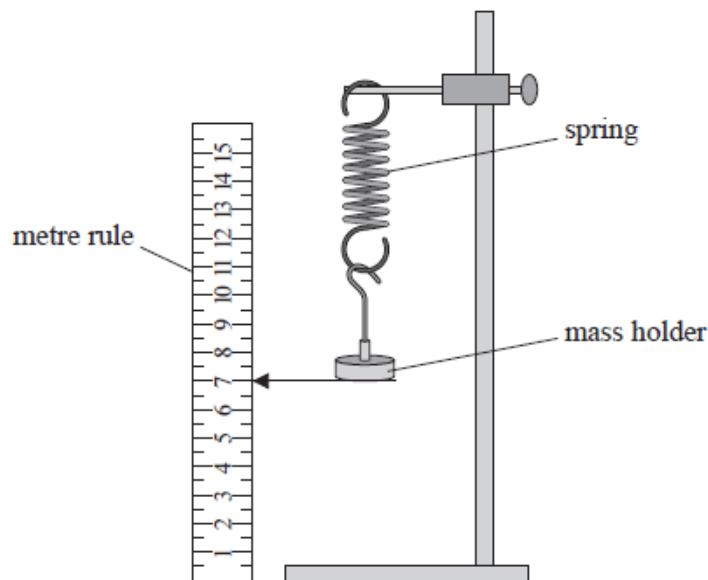

The position of the bottom of the mass holder was recorded. The spring was stretched by adding masses to the mass holder and the new positions were recorded. The extension of the spring each time was calculated.

The student produced the following table.

Mass added / g	Extension / cm	Stretching force / N
50	1.9	0.49
70	3	0.69
90	3.5	0.9
110	4.5	1.08
130	5.3	1.28
150	5.8	1.47

Two identical springs are joined in series and a bar magnet is hung from one end as shown.

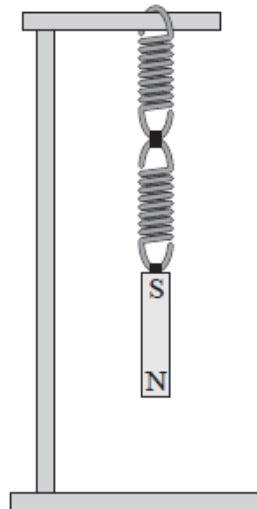

The bar magnet is displaced a small distance vertically from its equilibrium position and released.

Calculate the frequency at which the system oscillates.

mass of magnet = 120 g
 spring constant of each spring = 22 N m⁻¹

(4)

.....

.....

.....

.....

.....

.....

.....

.....

.....

.....

Frequency =

(Total for question = 4 marks)

Q15.

A liquid-crystal display uses a series of segments to form letters and numbers on a screen.

The construction of a display segment is shown.

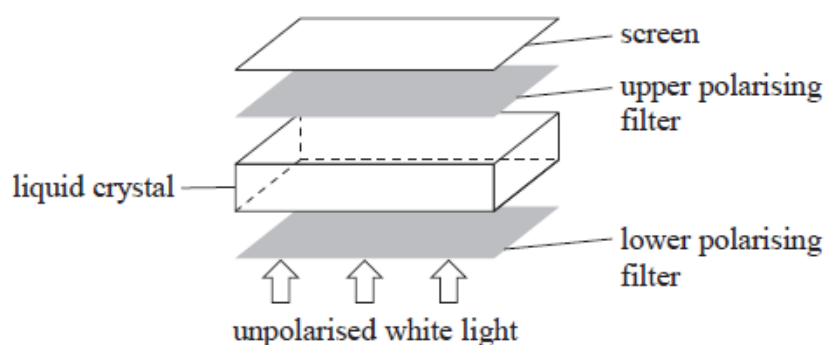

- Unpolarised white light passes through the lower polarising filter and becomes plane polarised.
- When there is no potential difference (p.d.) across the liquid crystal, the molecules in the liquid crystal rotate the plane of polarisation by 90° .
- Light then passes through the upper polarising filter and appears on the screen.
- When a p.d. is applied across the liquid crystal, the molecules no longer rotate the plane of polarisation. The light will not pass through the upper polarising filter and the screen appears dark.

Manufacturers are developing new materials for flexible screens for liquid-crystal displays. The graph shows how stress varies with strain for two materials X and Y up to typical stresses that would be applied to the screens in normal use. Both materials behave elastically over the ranges shown.

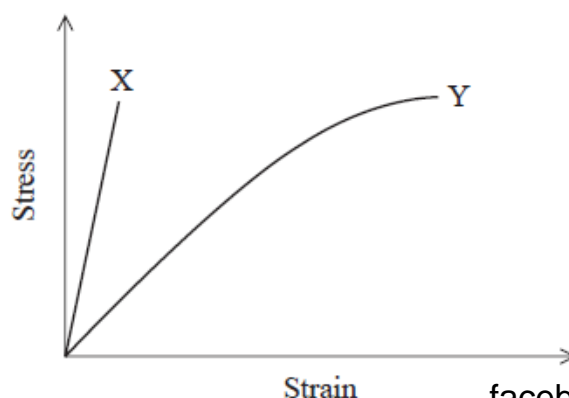

.....

.....

.....

.....

.....

.....

(ii) Hence calculate the extension of the copper wire.

(2)

.....

.....

.....

Extension =

(Total for question = 5 marks)

Q17.

Shrilk is a new material made from discarded shrimp shells. It is biodegradable and is easily moulded into different shapes. Shrilk is an alternative to polythene and could be used to make waste bags in the future.

The graph shows a stress-strain curve for a 25.0 cm length of shrilk and for a similar length of polythene, up to breaking point.

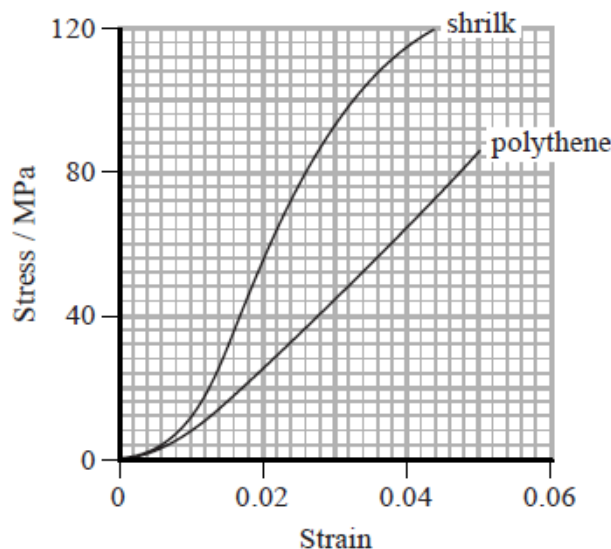

(a) (i) Calculate the force applied to the shrilk at a strain of 0.02

cross-sectional area = $1.2 \times 10^{-6} \text{ m}^2$

(3)

.....
.....
.....
.....

Force =

(ii) Determine the extension of the shrilk at a strain of 0.04

(2)

.....
.....
.....
.....
.....

Extension =

(b) Deduce whether shrilk or polythene is better for making waste bags.

(3)

.....
.....
.....
.....
.....
.....

(Total for question = 8 marks)

Q18.

* A resistance band is a length of an elastic material that can be used for exercise. The user repeatedly applies an increasing tensile force (loading) and then releases the force (unloading).



The force-extension graph for the resistance band is shown.

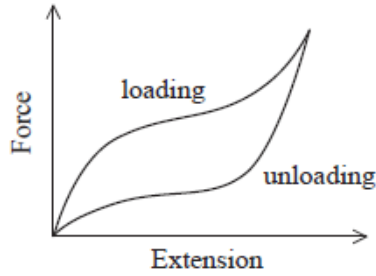

The user finds that the band gets warm during use.

Describe, with reference to the graph, the behaviour of the resistance band when it is repeatedly loaded and unloaded.

(6)

.....

.....

.....

.....

.....

.....

.....

.....

.....

.....

.....

.....

.....

.....

.....

.....

Q20.

The diagram shows a rock climber of mass 55 kg. She is hanging on a rope with one foot in contact with a rock face. She uses this foot to push herself horizontally away from the rock face. The rope is inclined at 20° to the vertical.



(a) Complete the free-body force diagram below to represent the forces acting on the climber.

(3)



(b) (i) Show that the tension in the rope is about 600 N.

(3)

.....

.....

.....

.....

.....

.....

.....

(ii) The rope extends by 2.5 cm when used as shown.

Calculate the energy stored within the rope.

(2)

.....

.....

Energy stored =

(iii) State one assumption made in this calculation.

(1)

.....

(Total for question = 9 marks)

Q21.

A medical scanner uses a moving table to position the patient. Strain gauges are used to monitor the shape of the table which enables a more precise positioning of the patient.



Strain gauges consist of a thin length of wire attached, in a zigzag pattern, to a small flexible piece of plastic. The strain gauge is attached to the table. When the table is subjected to forces, the dimensions of the plastic change. This causes a change in the length of the wire and hence a change in the resistance of the wire.

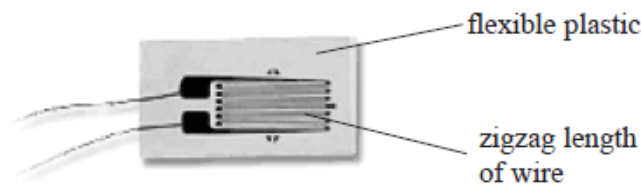

(a) Resistance can be measured directly using an ohmmeter or indirectly using measurements from a voltmeter and ammeter.

.....

(b) The diagram shows forces applied to a strain gauge. The 'width' of the strain gauge is defined by the distance w .

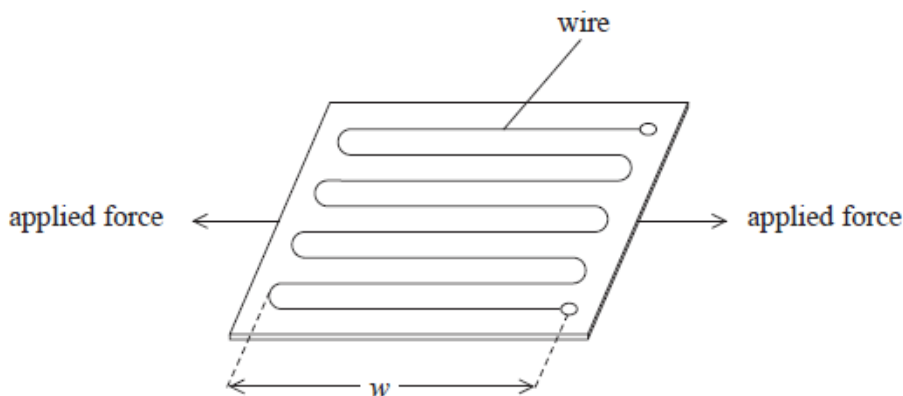

(i) State and justify how the applied forces change the resistance of the wire.

(2)

.....

(ii) The gauge factor GF of a strain gauge is given by

$$GF = \frac{\Delta R}{\epsilon R}$$

where ϵ is the strain

R is the initial resistance

ΔR is the change in resistance

When forces are applied to the strain gauge, the resistance of the gauge changes by 0.10%.

Calculate the change in the width of the strain gauge.

$w = 5.0 \text{ cm}$

$GF = 2.0$

(3)

.....

Change in width =

(c) Explain the benefit of arranging the wire in a zigzag pattern.

(2)

(Total for question = 9 marks)

Q22.

In 2016 scientists at the Laser Interferometer Gravitational-Wave Observatory (LIGO) announced that gravitational waves had been detected.

The signal they detected is shown on the graph.

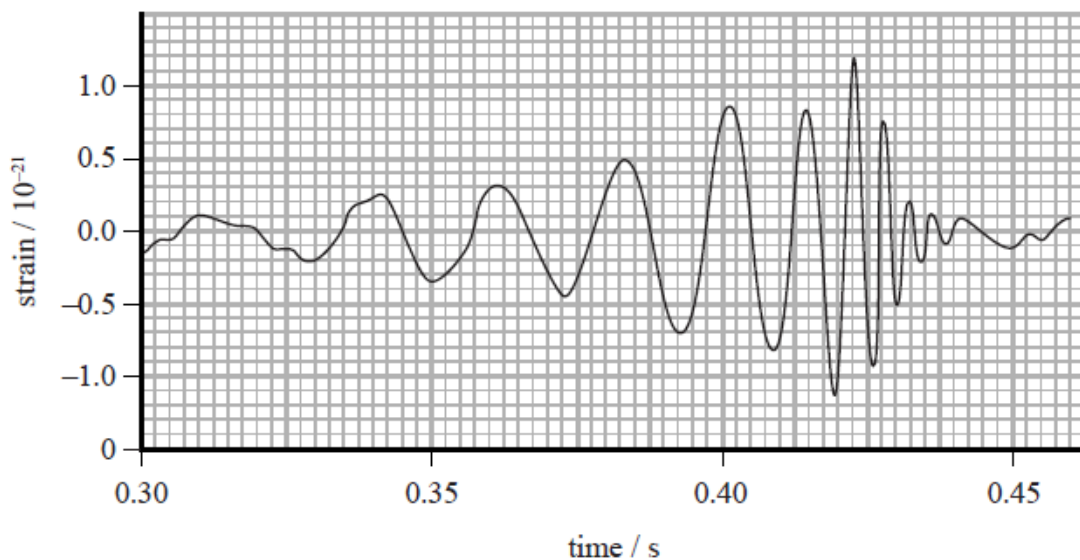

Gravitational waves alternately compress and stretch matter by very small amounts as they pass through.

The LIGO detector has two arms, at 90° to each other, each 4 km long. As a gravitational wave passes the detector, the arms change length. The detector continuously compares the lengths of the two arms.

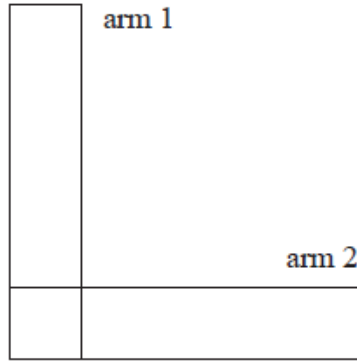

(i) An article states that 'the maximum change in the 4 km length of the arm is about 0.001 times the diameter of a proton'.

Determine whether this statement applies to the gravitational wave shown in the graph.

diameter of proton = 8.8×10^{-16} m

(3)

.....

.....

.....

.....

.....

.....

(ii) In the LIGO detector, any change in the lengths of the arms is detected using a laser beam and photodetector.

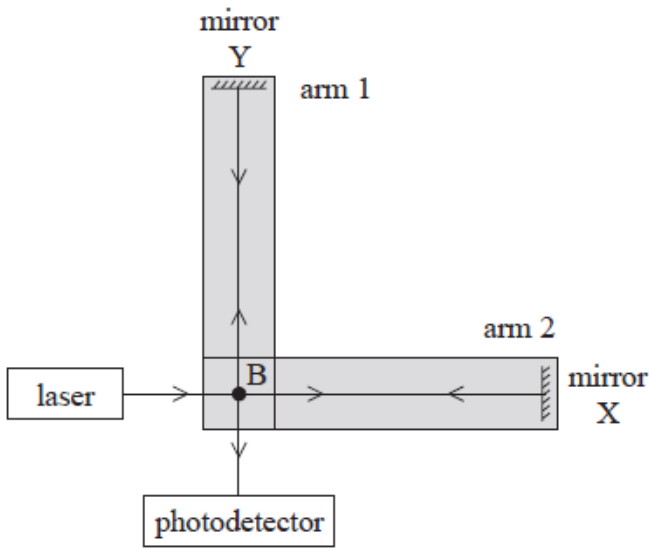

The laser beam is split into two at B, one beam travelling to one mirror and the other beam travelling to the other mirror. After reflection at the mirrors, the beams are recombined at B and reach the photodetector. The photodetector measures the intensity of the incident light.

The system is arranged so that when no gravitational waves are present, the beams have a path difference of half a wavelength at the photodetector.

Explain how the photodetector detects very small changes in the length of one arm, when the other arm stays the same length.

(4)

.....

.....

.....

.....

.....

.....

.....

.....

.....

.....

(iii) The system could be arranged so that when no gravitational waves are present, the beams have zero path difference at the photodetector.

Explain whether using an initial path difference of half a wavelength is a more sensitive way of detecting changes in length than having an initial path difference of zero.

(2)

.....

.....

.....

.....

.....

(Total for question = 9 marks)

Q23.

The graph shows the stress-strain curve for two types of human bone under compression.

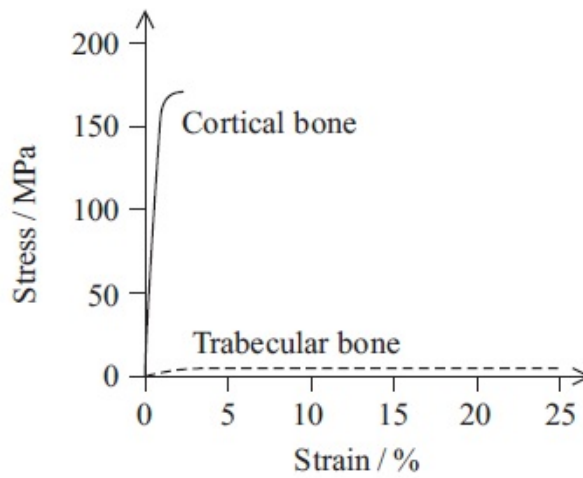

(a) Use the graph to identify and describe **one** property of cortical bone.

(2)

.....

.....

.....

.....

(b) The table gives the following information for the two types of bone.

Material	Young modulus / GPa	Maximum compressive stress / MPa	Maximum tensile stress / MPa
Cortical bone	17.9	170	120
Trabecular bone	0.076	2.2	

(i) State the difference between (i) compressive stress and tensile stress.

(1)

.....
.....
.....

(ii) State how the graph could be used to confirm the value of the Young modulus for cortical bone.

(1)

.....
.....

(iii) A person of mass 90 kg stands on one foot. Show that the maximum weight which can be supported is about 70 times this person's weight. Assume all the weight is supported by the femur (thigh bone) and that it is made of cortical bone.

cross-sectional area of femur = $3.7 \times 10^{-4} \text{ m}^2$

(4)

.....
.....
.....
.....
.....
.....
.....
.....
.....

(iv) It is stated in a text book that a femur can support about 30 times a person's weight.

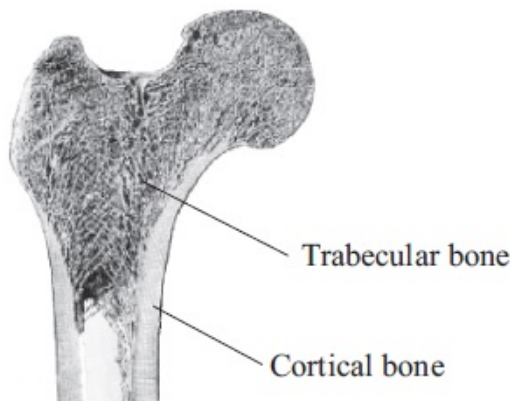

Explain how the structure shown in the diagram would account for the difference from the calculated value.

(2)

.....

.....

.....

.....

.....

.....

(Total for question = 10 marks)

Q24.

The diagram shows the equipment a student used to investigate the behaviour of a material in the form of a wire under an increasing tension.

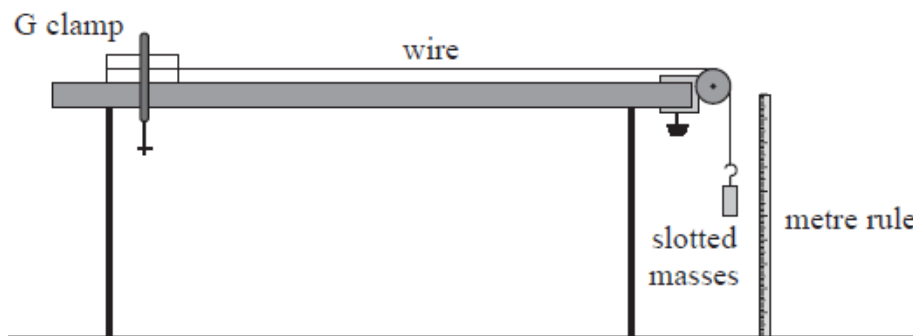

Masses were added up to a maximum of 3.30 kg. Each time a mass was added the extension of the wire was calculated.

(a) The following mass-extension graph was obtained.

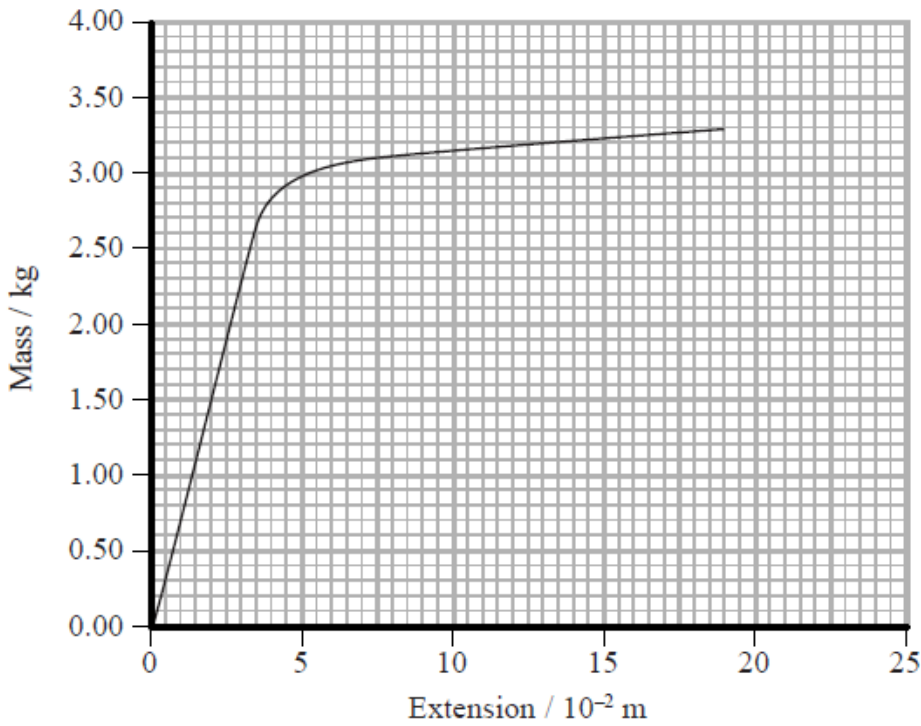

(i) Initially the extension increased linearly.

State what is meant by 'increased linearly' in relation to this graph and what can be concluded about the wire from this observation.

(2)

.....

.....

.....

.....

(ii) Use the graph to calculate the maximum energy that the wire could store while behaving linearly.

(3)

.....

.....

.....

.....

.....

Maximum energy =

(iii) Describe the behaviour of the wire when the added mass was greater than 2.9 kg.

(2)

.....
.....
.....
.....

(b) The student modifies the investigation.

(i) Suggest **one** modification that would produce a greater extension for a given mass.

(1)

.....
.....

(ii) Suggest **two** measuring techniques that could be used to ensure the accuracy of the measured extensions.

(2)

.....
.....
.....
.....
.....

(Total for question = 10 marks)

Q25.

The forces between the two atoms in a molecule of hydrogen can be modelled using a spring. When in equilibrium the nuclei are separated by $1.12 \times$ diameter of the atom.

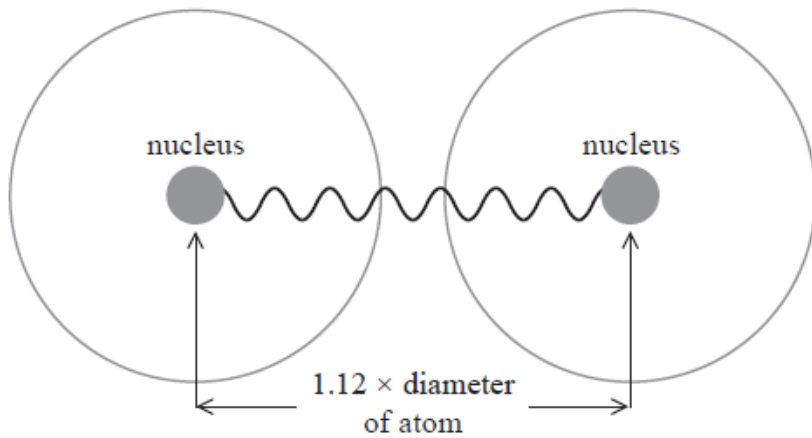

(a) When the atoms are squashed together by a force F , the spring is under compression.

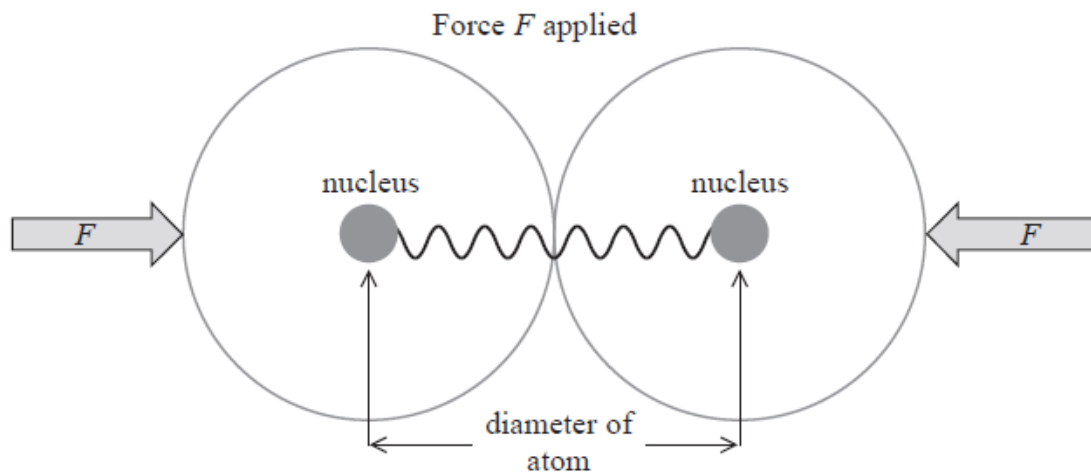

When the force F acts on the atoms, the separation between the nuclei becomes equal to the diameter of the atom.

Calculate the force F .

spring constant for hydrogen = 1130 N m^{-1}

diameter of an atom of hydrogen = $1.06 \times 10^{-10} \text{ m}$

(3)

.....

.....

.....

.....

.....

Force =

(b) A student carries out an experiment to model the forces between atoms.

A varying force is applied to the end of a spring. The student measures the length of the spring and calculates the extension for each force applied.

The student plots the following graph.

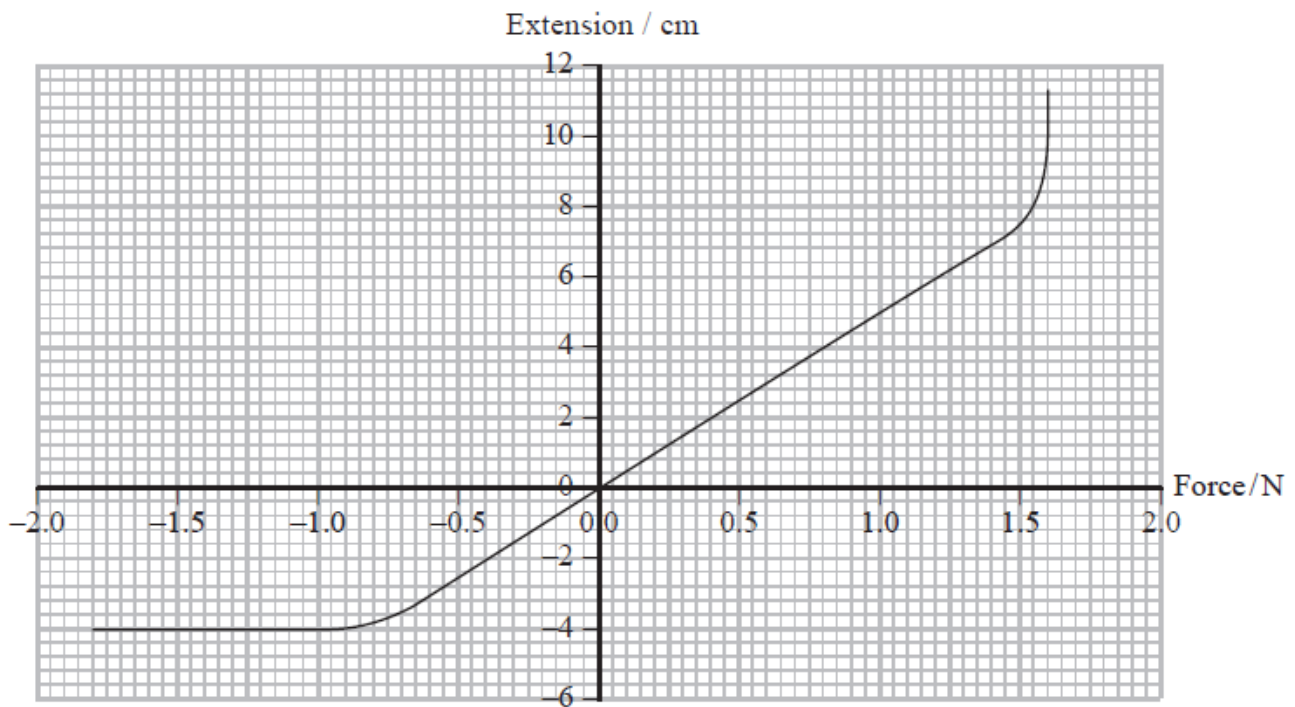

(i) Explain the shape of the graph.

(3)

.....

.....

.....

.....

.....

.....

.....

.....

(ii) Use the graph to calculate the spring constant.

(2)

.....

.....

.....

.....

Spring constant =

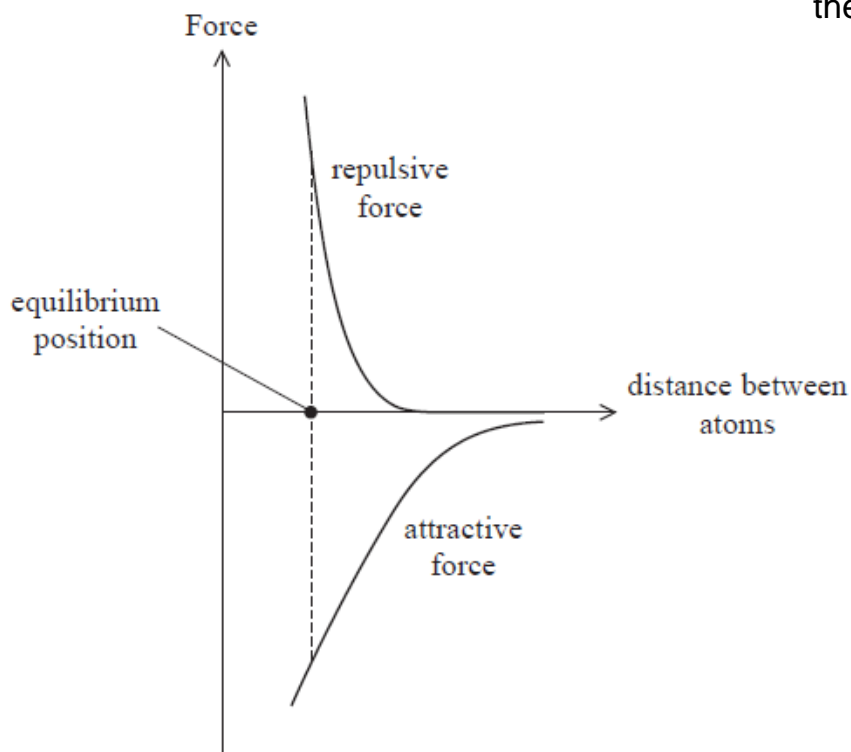

Use the graph to explain why the forces between atoms are attractive when they are pulled apart and repulsive when pushed together.

(3)

.....

.....

.....

.....

.....

.....

(Total for question = 11 marks)

Q26. The photographs show an exercise device and someone using it. The device contains two rubber cords which are extended when the device is used.



A student investigates the properties of the device by hanging weights on it and measuring the extension.

The student obtains the following graph for her results.

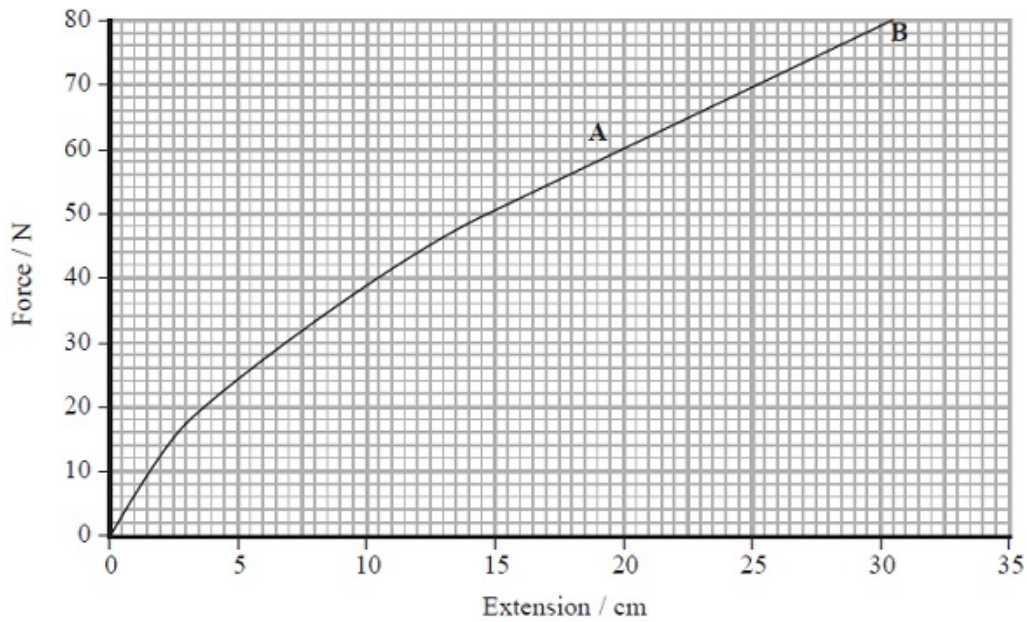

(a) The student notices that her graph is a straight line between A and B and concludes that the device obeys Hooke's law.

Comment on this conclusion.

(2)

.....

.....

.....

(b) (i) Describe how the student could use the graph to obtain an estimate of the total work done.

(ii) The student sets up a spreadsheet to investigate the work done in stretching the device each time a weight is added.

	A	B	C	D
1	Total stretching force / N	Extension / cm	Change in extension / m	Work done (force × change in extension) / J
2	0	0.0	0.000	0.00
3	10	1.6	0.016	0.16
4	20	3.5	0.019	0.38
5	30	7.0	0.035	1.05
6	40	10.5	0.035	1.40
7	50	14.5	0.040	2.00
8	60	20.0	0.055	3.30
9	70	25.2	0.052	3.64
10	80	30.5	0.053	4.24
11			Total work done	16.17

Explain why this spreadsheet results in an over-estimate for the total work done.

(2)

(c) The student eats a packet of crisps and then uses the exercise device. The energy content in a packet of crisps is 540 kJ. During exercise this energy is converted and 25% of it is transferred to mechanical work.

The student extends the device fully 15 times in 1 minute. An accurate value for the work done in fully extending the device is 14.7 J.

Calculate the time it would take the student, working at this rate, to transfer 25% of the energy from the crisps to mechanical work.

(3)

.....

Time =

(d) Explain whether more or less work would be done applying the same maximum total stretching force to a similar exercise device with rubber cords of twice the cross-sectional area.

(2)

.....

(Total for Question = 11 marks)

Q27. Pile drivers have been used for centuries to push piles into the ground for use as foundations of buildings and other structures. A large mass (the driver) is raised and then dropped onto an object (the pile) which is pushed into the ground.

The picture shows the pile driver that was used to build a London bridge in the 17th century.

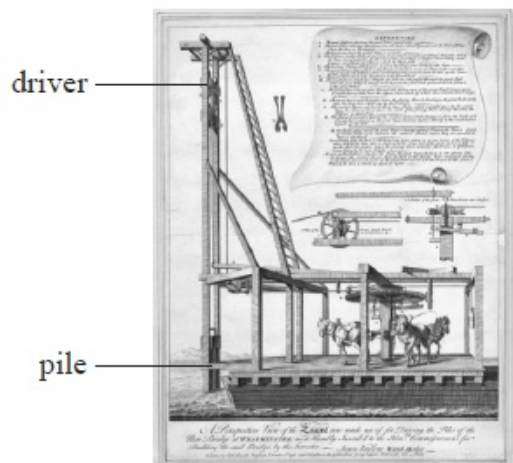

(a) (i) The driver on the pile driver above had a mass of 810 kg and could be dropped a maximum distance of 6.0 m onto the pile.

Show that the energy transferred from the driver is about 50 kJ.

(2)

.....

(ii) In one instance, 40% of this energy is used usefully to drive in the pile. The pile moves 0.20 m into the ground.

Determine the average resistive force acting on the pile as it moves through the ground.

(3)

.....

.....

.....

.....

.....

.....

Average resistive force =

(b) In order to protect the driver on modern pile drivers, a cushion made of wood is placed on the pile.

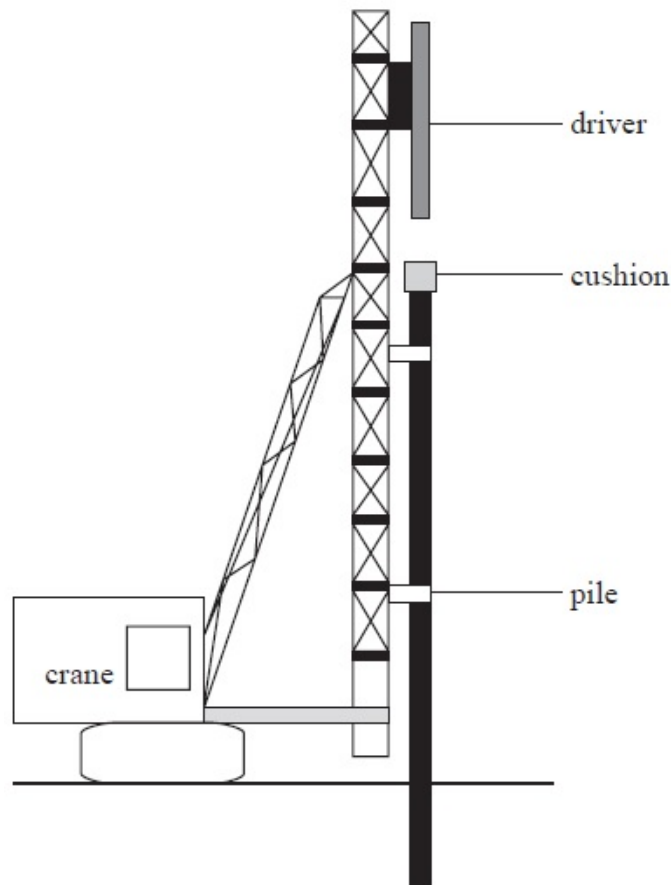

The cushion is a cylindrical piece of wood of Young modulus = 120 MPa

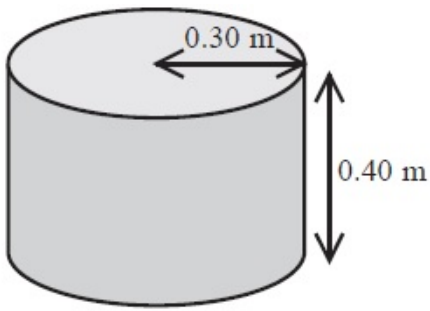

The cushion is compressed when hit by the driver.

(i) The maximum compressive force applied to the wood during impact is 7.0×10^5 N. Show that the compression of the cushion is about 0.01 m.

(3)

.....

.....

.....

.....

.....

(ii) Calculate the energy stored in the cushion under compression.

(2)

.....

.....

.....

Energy stored =

*(iii) The graph shows how the compression of the wooden cushion varies with force, as the force is applied and removed during an impact.

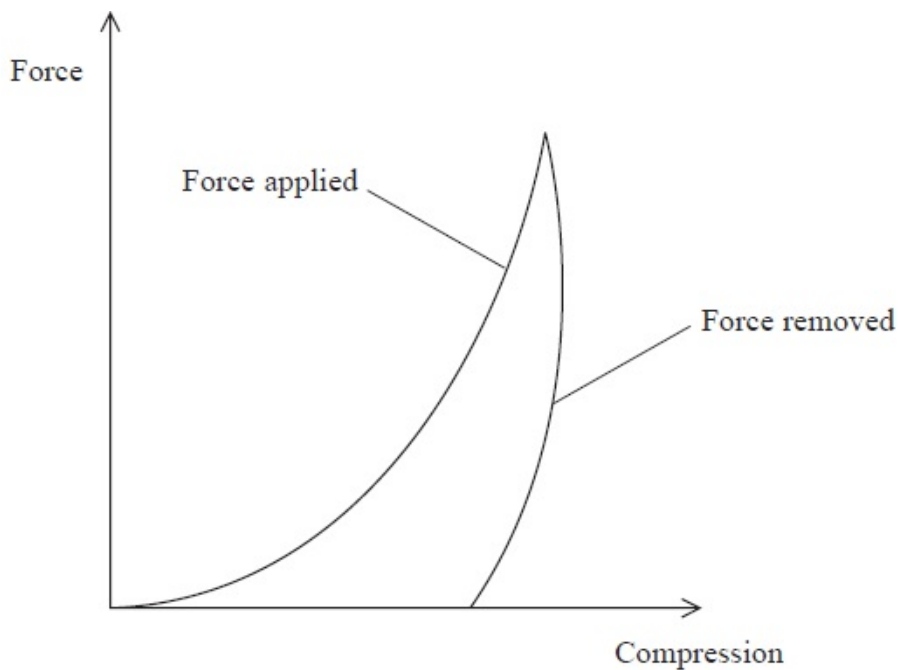

Use the graph to explain the following:

1. the wooden cushion has to be replaced after a few hundred impacts,

(2)

.....

.....

.....

.....

2. with each impact the temperature of the wooden cushion rises slightly.

(1)

.....

.....

(Total for Question = 13 marks)

Q28.

The following three properties can be used to describe copper.

Ductile Malleable Tough

(a) Both nylon and copper can be used to make fishing lines. Copper fishing lines sink faster than those made of nylon. This makes copper fishing lines more suitable for deep water fishing.

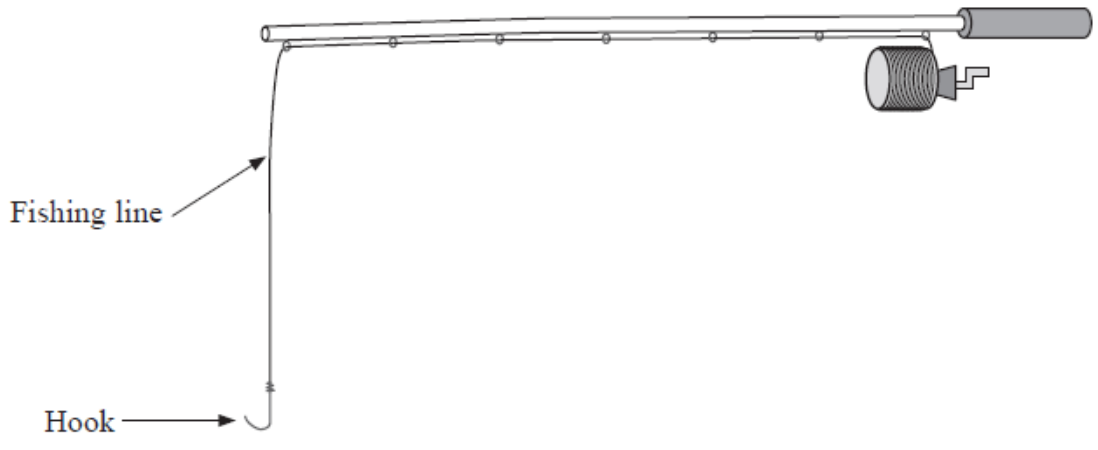

(i) By considering the forces acting on the submerged line, explain why nylon is less suitable than copper for deep water fishing. Include a suitable calculation in your answer.

Both lines have the same cross-sectional area.

cross-sectional area of lines = $1.30 \times 10^{-7} \text{ m}^2$

density of saltwater = 1030 kg m^{-3}

weight of 20.0 m of copper line = 0.220 N

weight of 20.0 m of nylon line = 0.0280 N

(4)

.....

.....

.....

.....

.....

.....

.....

.....

.....

(ii) A fish becomes caught on the hook and the copper line extends. Calculate the extension produced.

cross-sectional area of copper line = $1.30 \times 10^{-7} \text{ m}^3$

load on line = 65.0 N

original length of line = 20.0 m

Young modulus of copper = 129 GPa

.....

.....

.....

.....

.....

Extension =

(b) Some people use fishing lines that have been pre-stretched by loading and unloading.

(i) Sketch the force-extension graph for a copper line during the process of pre-stretching.

(3)

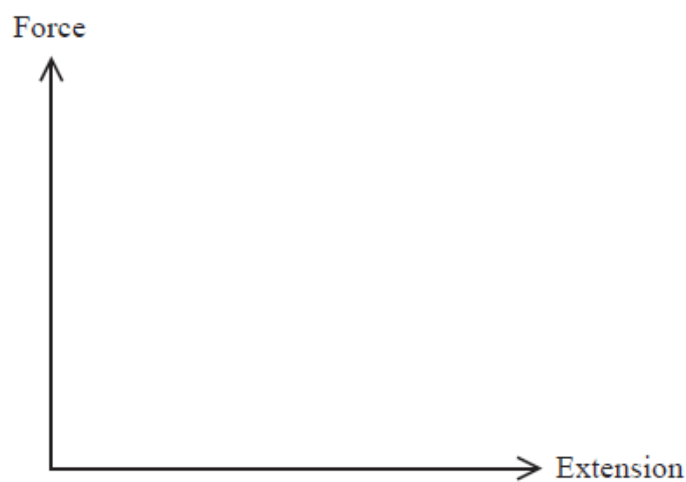

(ii) Suggest a reason why some people prefer to use this type of line.

(1)

.....

.....

.....

.....

(Total for question = 11 marks)

Q29.

A school dynamics trolley has a plunger attached to a spring. When the plunger is pushed in, the spring is compressed. When the plunger is released, it is pushed back out by the spring.

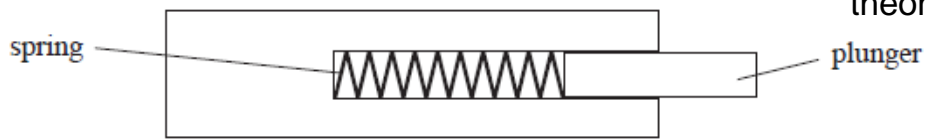

(a) A student investigated the spring to determine whether it obeys Hooke's law in compression.

The trolley was placed vertically in front of a scale and weights were added in turn to the top of the plunger, as shown. The position of the end of the plunger was recorded each time.



The recorded results are shown in the table.

Weight / N	Position of plunger / cm	
0.00	37.3	
2.00	37.0	
4.00	36.6	
6.00	36.2	
8.00	35.9	
10.00	35.5	

(i) Use the results to plot a graph of weight against compression. You may use the additional column for your processed data.

(5)

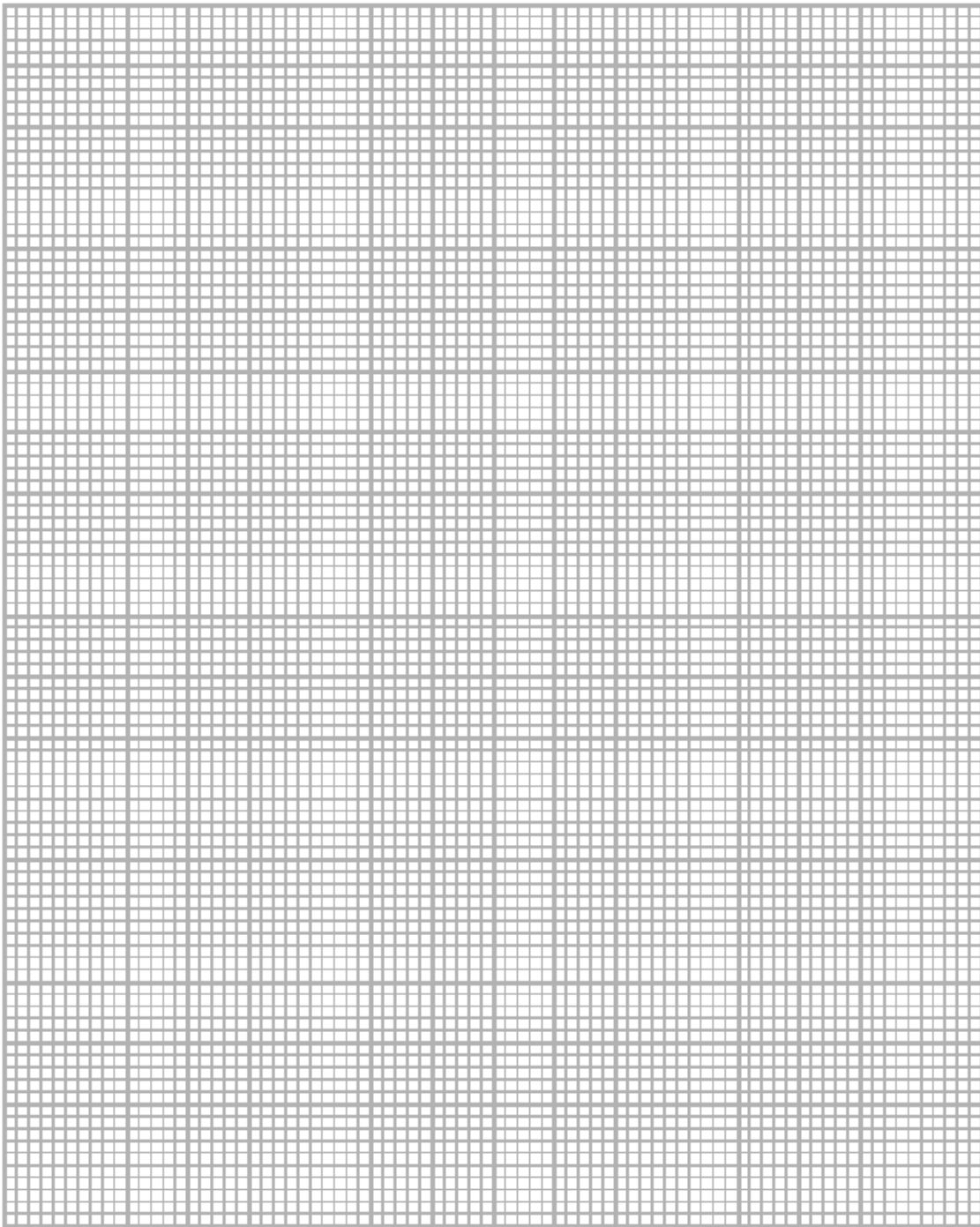

(ii) The student concluded that the spring obeys Hooke's law with a spring constant of about 600 N m^{-1} .

Determine whether the student's conclusion is justified.

(4)

.....

.....

.....

.....

.....

.....

.....
.....
(b) Another trolley was adapted by placing a tube around the plunger so that it could be used to launch marbles. A marble was placed in the tube while the plunger was depressed. When the plunger was released it launched the marble.

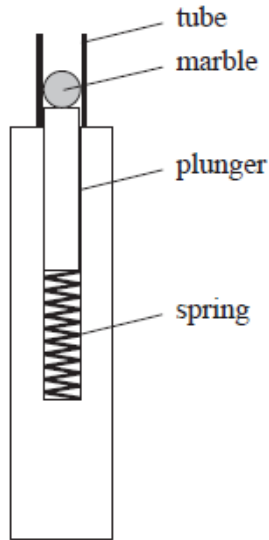

Determine the maximum possible launch velocity of the marble when the spring is compressed by 5.4 cm.

spring constant = 610 N m^{-1}

mass of marble = 4.1 g

mass of plunger = 35.4 g

(4)

.....
.....
.....
.....
.....
.....
.....

Maximum launch velocity =

(c) The launch velocity was measured using a light gate and data logger. This produced a smaller value for the launch velocity than that calculated in (b).

Give a reason why this method produced a smaller value for the launch velocity.

(1)

.....

.....

(Total for question = 14 marks)