



**Pressure and pressure differences  
in fluids**

Questions

Name: \_\_\_\_\_

Class: \_\_\_\_\_

Date: \_\_\_\_\_

---

Time: **78 minutes**

Marks: **77 marks**

Comments:

---

1

Musicians sometimes perform on a moving platform.

The figure below shows the parts of the lifting machine used to move the platform up and down.

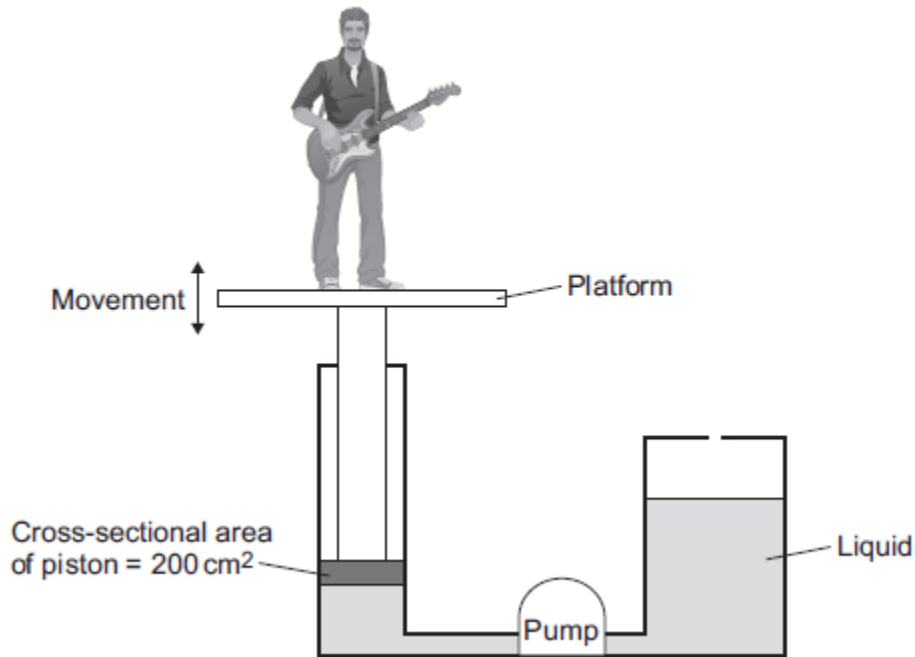

(a) What name is given to a system that uses liquids to transmit forces?

Draw a ring around the correct answer.

- electromagnetic**
**hydraulic**
**ionising**

(1)

(b) To move the platform upwards, the liquid must cause a force of 1800 N to act on the piston.

The cross-sectional area of the piston is 200 cm<sup>2</sup>.

Calculate the pressure in the liquid, in N / cm<sup>2</sup>, when the platform moves.

---



---



---

Pressure = \_\_\_\_\_ N / cm<sup>2</sup>

(2)

(c) A new development is to use oil from plants as the liquid in the machine.

Growing plants and extracting the oil requires **less energy** than producing the liquid usually used in the machine.

Draw a ring around the correct answer to complete the sentence.

Using the oil from the plants gives

- an environmental
- an ethical
- a social

advantage over the

liquid usually used.

(1)

(Total 4 marks)

2

Mountain bike riders use brakes to slow down.



© Ljupco Smokovski/Shutterstock

Some mountain bikes have hydraulic brakes.

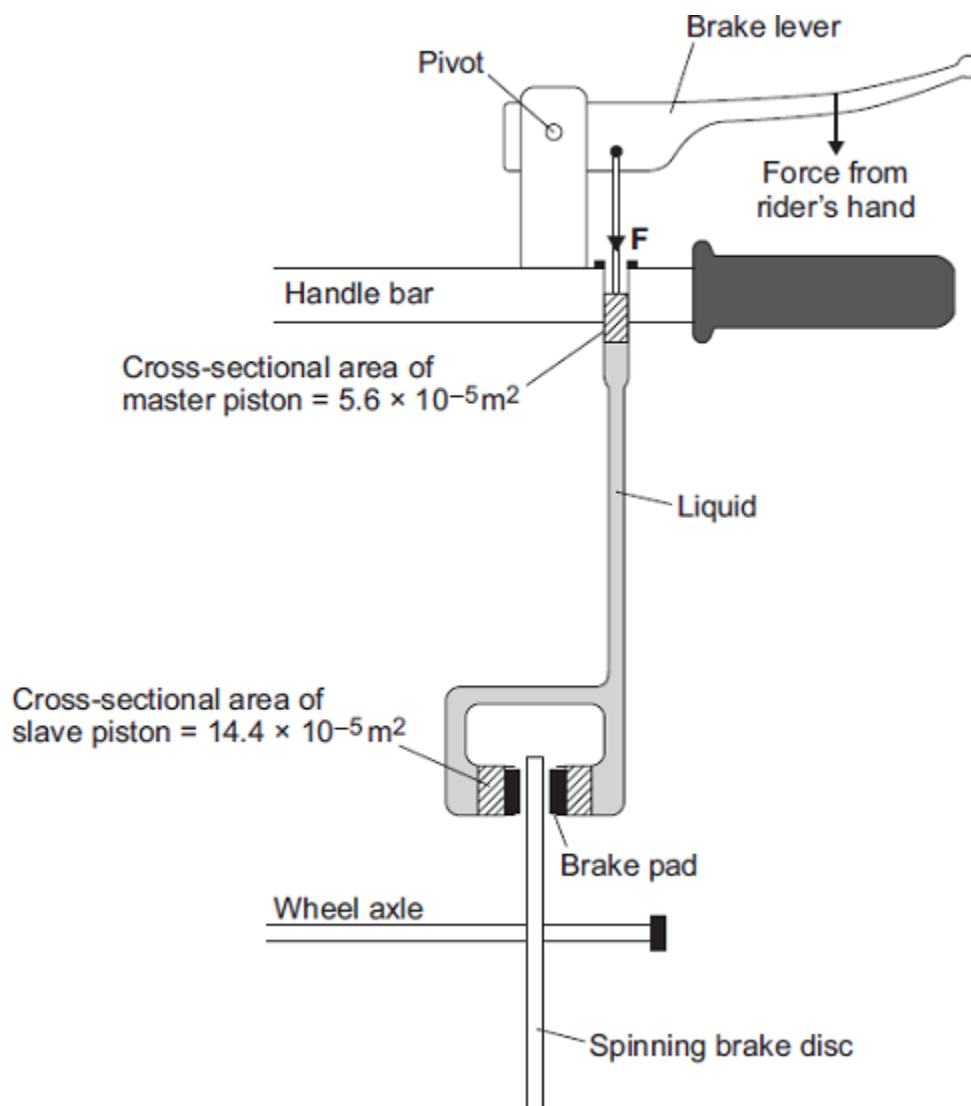

- (a) What property of a liquid enables a hydraulic brake system to work?

---

(1)

- (b) When the rider's hand pulls on the brake lever, the master piston applies a pressure of  $1.5 \times 10^6$  pascals to the liquid.

Using information from the diagram, calculate the force **F** exerted on the liquid by the master piston.

---



---



---



---

Force **F** = \_\_\_\_\_ N

(2)

- (c) The pressure in the liquid applies a force to move each slave piston.

How does the size of this force compare to the force **F** applied by the master piston?

---



---

Give a reason for your answer.

---



---

(2)

(Total 5 marks)

3

Mountain bike riders use brakes to slow down.



© Ljupco Smokovski/Shutterstock

Some mountain bikes use liquid-filled pipes to transmit the force from the rider's hand on the brake lever to the brake pads. These brakes are called hydraulic brakes.

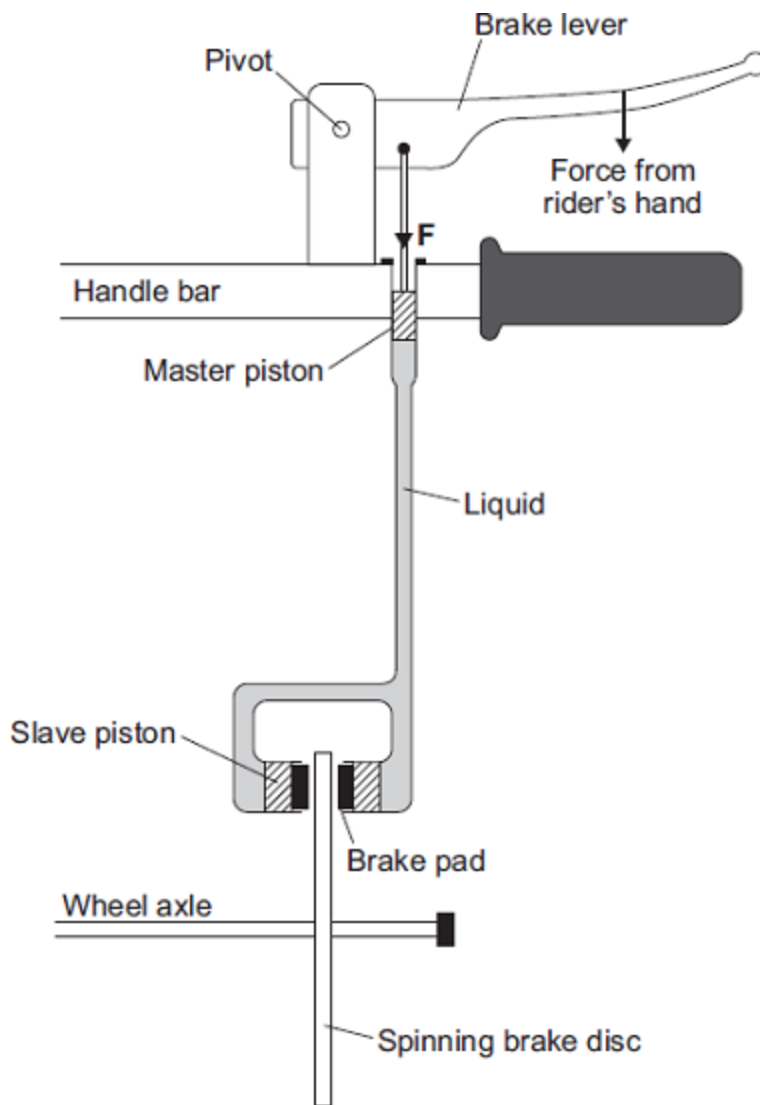

(a) Draw a ring around the correct answer to complete each sentence.

(i) Liquids can be used to transmit the forces in a brake system,

because liquids

- are incompressible.
- can flow.
- take the shape of the container.

(ii) The pressure in the liquid is transmitted

- against force **F** only.
- downwards only.
- in all directions.

(1)

(1)

- (b) When the rider's hand pulls on the brake lever, the force **F** applied to the liquid by the master piston is 80 N. The cross-sectional area of this piston is 50 mm<sup>2</sup>.

Calculate the pressure, in N/mm<sup>2</sup>, exerted on the liquid by the master piston.

---



---



---

Pressure = \_\_\_\_\_ N/mm<sup>2</sup>

(2)

- (c) The unit N/mm<sup>2</sup> is **not** the usual unit of pressure.

Which unit is usually used when calculating pressure?

Draw a ring around the correct answer.

N

Nm<sup>2</sup>

Pa

(1)

- (d) The rider applies a larger force to the brake lever. How would this increase in force affect the pressure in the liquid?

---

(1)

(Total 6 marks)

4

The figure below is a simplified diagram of a hydraulic brake system.

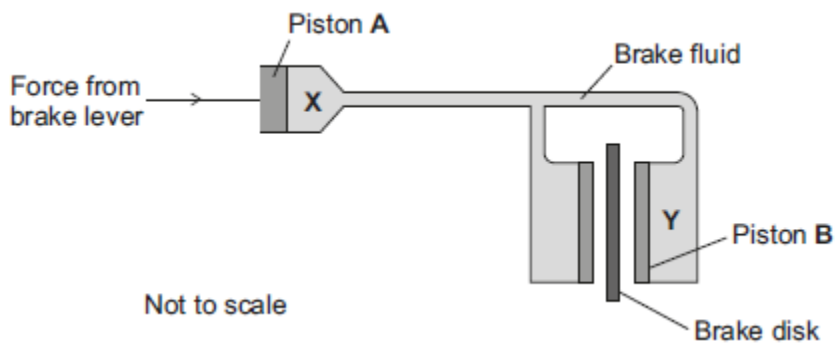

(a) Which is the correct statement about the pressure at **X** and the pressure at **Y**?

Tick (✓) **one** box.

The pressure at **X** is greater than at **Y**

The pressure at **X** is the same as at **Y**

The pressure at **X** is less than at **Y**

(1)

(b) Piston **B** is larger than piston **A**.

How will this affect the size of the force on piston **B**?

Use the correct answer from the box to complete the sentence.

<b>smaller than</b>	<b>the same as</b>	<b>larger than</b>
---------------------	--------------------	--------------------

The force on piston **B** will be \_\_\_\_\_ the force on piston **A**.

(1)

(c) (i) A force of 24 N acts on piston **A**. The cross-sectional area of piston **A** is 8 mm<sup>2</sup>.

Calculate the pressure in N/mm<sup>2</sup> at position **X**.

---



---



---



---

Pressure = \_\_\_\_\_ N/mm<sup>2</sup>

(2)

- (ii) The unit  $\text{N/mm}^2$  is not often used to measure pressure.

Which unit is usually used to measure pressure?

Tick (✓) **one** box.

newton

pascal

watt

(1)

- (d) The liquid used in the hydraulic brake system freezes at  $-30\text{ }^\circ\text{C}$ .

Suggest **one** effect a temperature below  $-30\text{ }^\circ\text{C}$  would have on the brake system.

---

---

(1)

(Total 6 marks)

5

Some students fill an empty plastic bottle with water.

The weight of the water in the bottle is 24 N and the cross-sectional area of the bottom of the bottle is  $0.008\text{ m}^2$ .

- (a) Calculate the pressure of the water on the bottom of the bottle and give the unit.

---

---

Pressure = \_\_\_\_\_

(3)

- (b) The students made four holes in the bottle along a vertical line. They put the bottle in a sink. They used water from a tap to keep the bottle filled to the top.

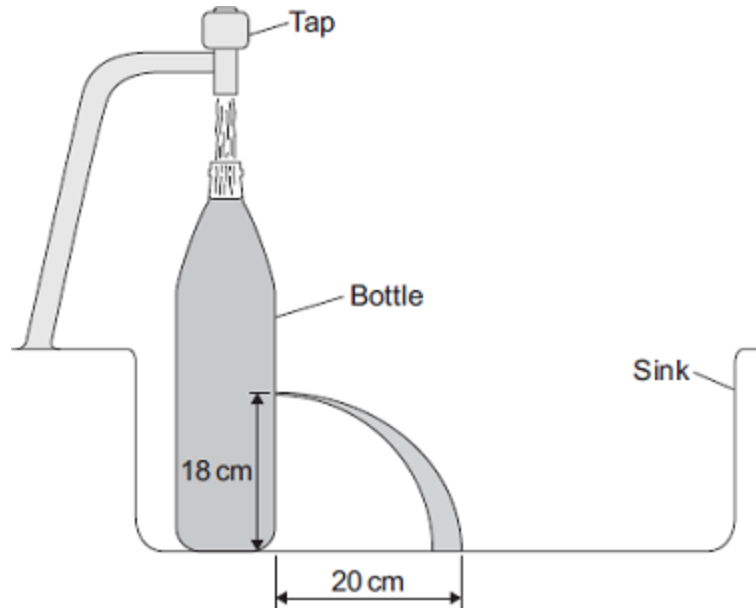

The students measured and recorded the vertical heights of the holes above the sink. They also measured the horizontal distances the water landed away from the bottle. A pair of measurements for one of the holes is shown in the diagram.

The complete data from the experiment is shown in the table.

Hole	Vertical height in cm	Horizontal distance in cm
J	24	15
K	18	20
L	12	30
M	6	40

- (i) Which hole is shown in the diagram?

Draw a ring around the correct answer.

**J**

**K**

**L**

(1)

(ii) On the diagram, draw the path of the water coming out of hole **M**.

Use the information in the table to help you.

(2)

(c) Suggest **one** problem that might arise from trying to collect data from a fifth hole with a vertical height of 1 cm above the sink.

---



---

(1)

(Total 7 marks)

**6**

Before a new bus can be used on the roads, it must pass a stability test.

**Figure 1** shows how the bus is tested.

**Figure 1**

**Front view**

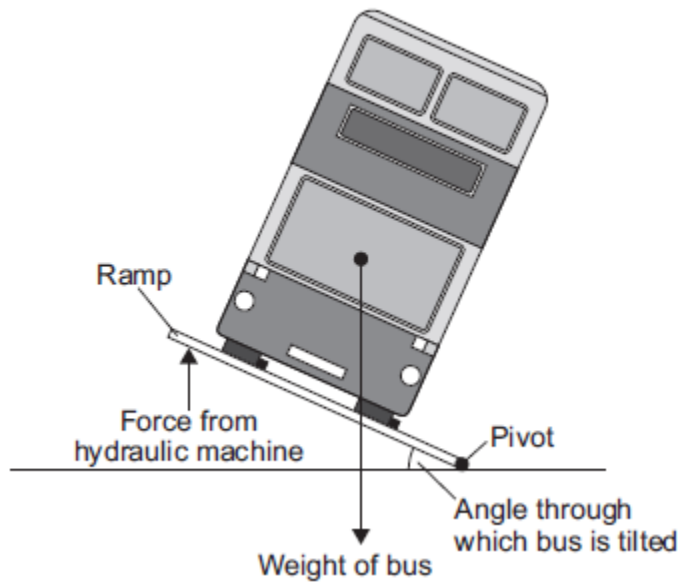

(a) (i) The bus will topple over if the ramp is tilted at too great an angle.

Explain why.

---



---



---



---

(2)

(ii) The bus is tested to angles of tilt far greater than it would experience in normal use.

Suggest **two** reasons why.

1. \_\_\_\_\_

\_\_\_\_\_

2. \_\_\_\_\_

\_\_\_\_\_

(2)

(b) **Figure 2** shows the hydraulic machine that is used to make the ramp tilt.

**Figure 2**

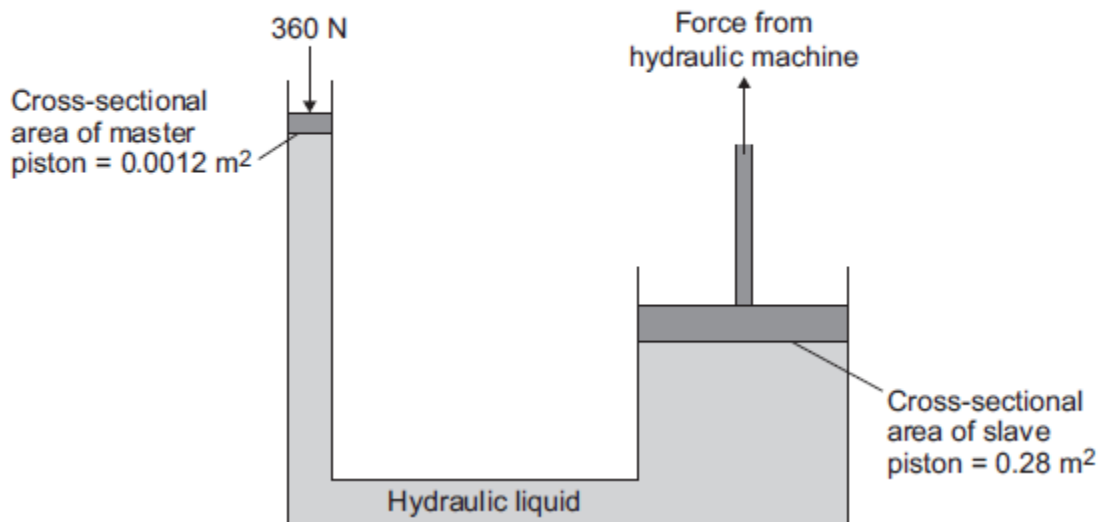

The pressure applied to the hydraulic liquid at the master piston is the same as the pressure applied by the hydraulic liquid to the slave piston.

(i) State the property of the liquid that keeps the pressure at both pistons the same.

\_\_\_\_\_

(1)

(ii) A 360 N force acts on the master piston.

Use information from **Figure 2** to calculate the force applied by the hydraulic liquid to the slave piston.

---



---



---



---

Force = \_\_\_\_\_ N

(3)  
(Total 8 marks)

7

Musicians sometimes perform on a moving platform.

**Figure 1** shows the parts of the lifting machine used to move the platform up and down.

**Figure 1**

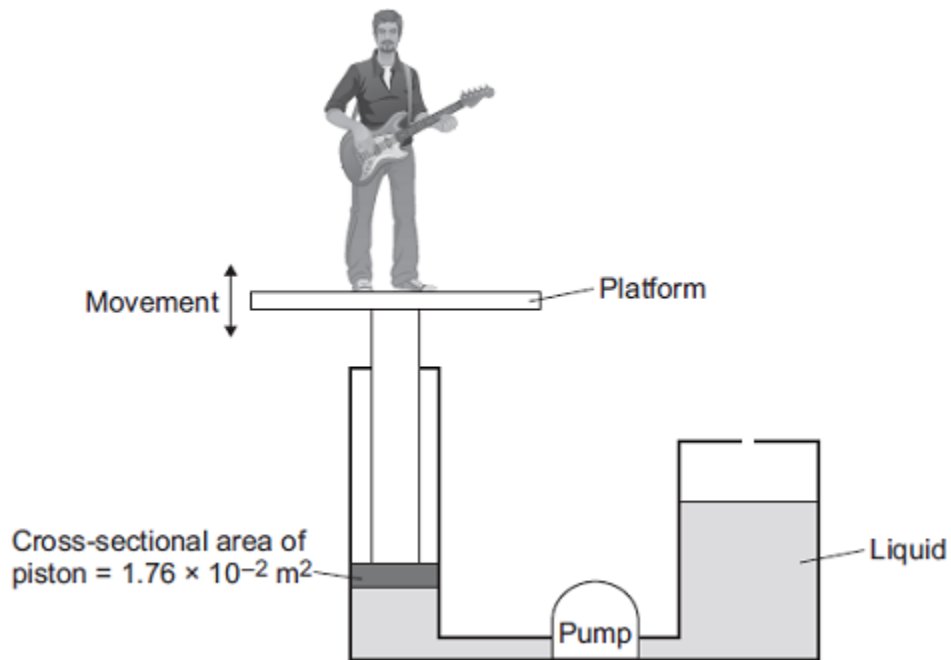

(a) What type of system uses a liquid to transmit a force?

---

(1)

- (b) The pump creates a pressure in the liquid of  $8.75 \times 10^4$  Pa to move the platform upwards.

Calculate the force that the liquid applies to the piston.

---

---

---

Force = \_\_\_\_\_ N

**(2)**

- (c) The liquid usually used in the machine is made by processing oil from underground wells. A new development is to use plant oil as the liquid.

Extracting plant oil requires less energy than extracting oil from underground wells.

Suggest an environmental advantage of using plant oil.

---

---

---

**(1)**

(d) Musicians often use loudspeakers.

Figure 2 shows how a loudspeaker is constructed.

Figure 2

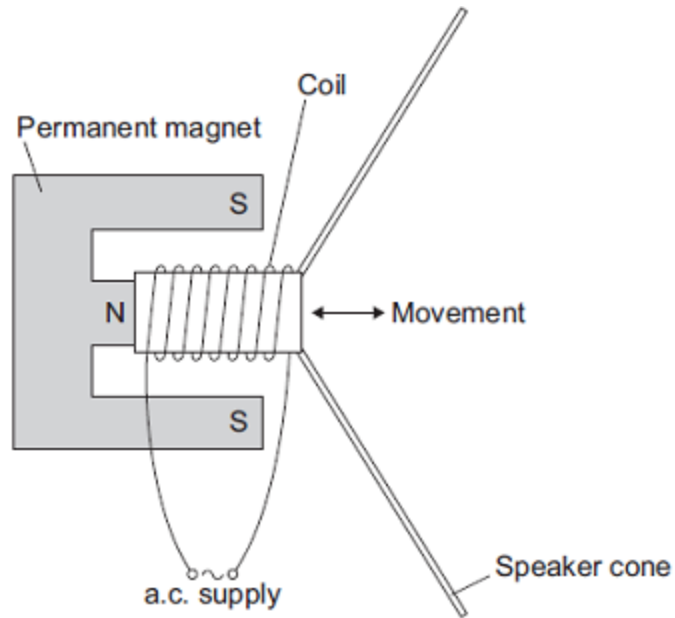

The loudspeaker cone vibrates when an alternating current flows through the coil.

Explain why.

---

---

---

---

---

---

---

---

---

---

---

---

(4)  
(Total 8 marks)

8

Levers and hydraulic systems can act as force multipliers.

(a) **Figure 1** shows a girl trying to lift a large rock using a long rod as a lever.

**Figure 1**

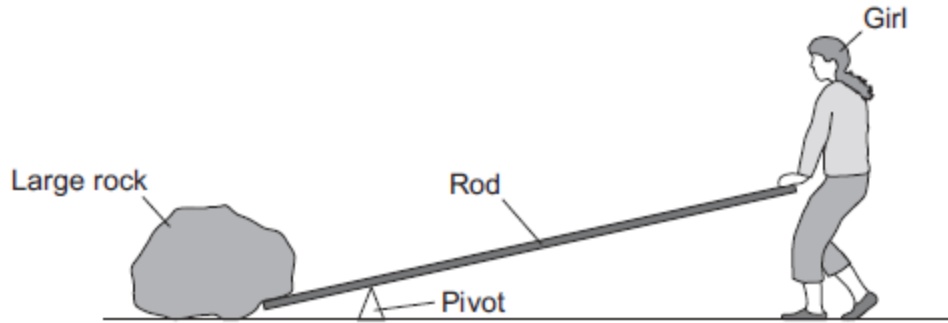

The girl is pushing down on the rod but is just unable to lift the rock.

Which of the following changes would allow her to lift the rock?

Tick (✓) **two** boxes.

Change	Tick (✓)
Move the pivot away from the rock	
Make the rod longer	
Push the rod upwards	
Push down on the rod with a greater force	

(2)

(b) Liquids are used in hydraulic systems because they are virtually incompressible.

Explain how the spacing of particles in a liquid cause it to be virtually incompressible.

---



---



---



---

(2)

(c) **Figure 2** shows a man using a car jack to lift his car.

**Figure 2**



© lisafx/iStock/Thinkstock

**Figure 3** shows a simple diagram of a car jack.

**Figure 3**

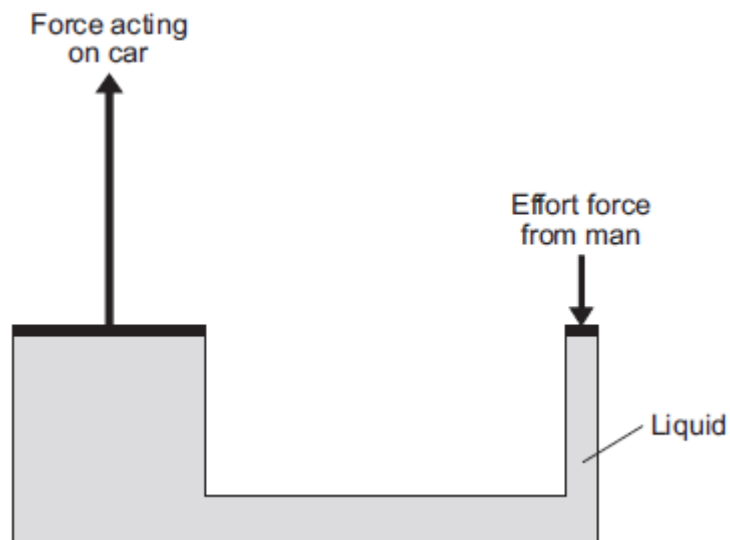

- (i) The man pushes down with an effort force. This results in a much larger force acting upwards on the car.

Use information from **Figure 3** to explain how.

---



---



---



---



---



---



---



---

(4)

- (ii) Which of the following statements about the forces in **Figure 3** is correct?

Tick (✓) **one** box.

	Tick (✓)
The force acting on the car moves a greater distance than the effort force.	
The force acting on the car moves less distance than the effort force.	
The force acting on the car moves the same distance as the effort force.	

(1)

(Total 9 marks)

9

Figure 1 shows how atmospheric pressure varies with altitude.

Figure 1

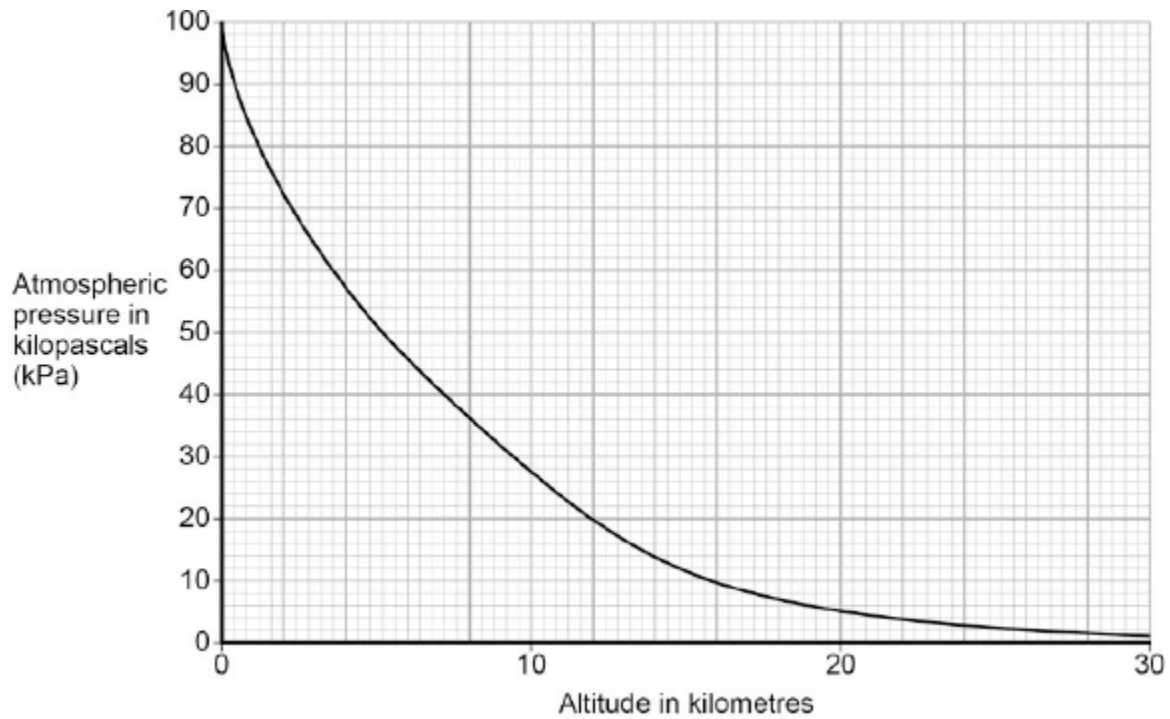

(a) Explain why atmospheric pressure decreases with increasing altitude.

---



---



---



---



---



---

(3)

(b) When flying, the pressure inside the cabin of an aircraft is kept at 70 kPa.

The aircraft window has an area of 810 cm<sup>2</sup>.

Use data from **Figure 1** to calculate the resultant force acting on an aircraft window when the aircraft is flying at an altitude of 12 km.

Give your answer to two significant figures

---



---



---



---



---



---

Resultant force = \_\_\_\_\_ N

(5)

(c) **Figure 2** shows the cross-section of one type of aircraft window.

**Figure 2**

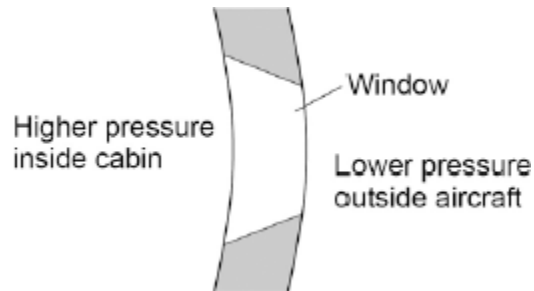

Explain why the window has been designed to have this shape.

---



---



---

(2)

(Total 10 marks)

10

The diagram shows a water butt used to collect rainwater.

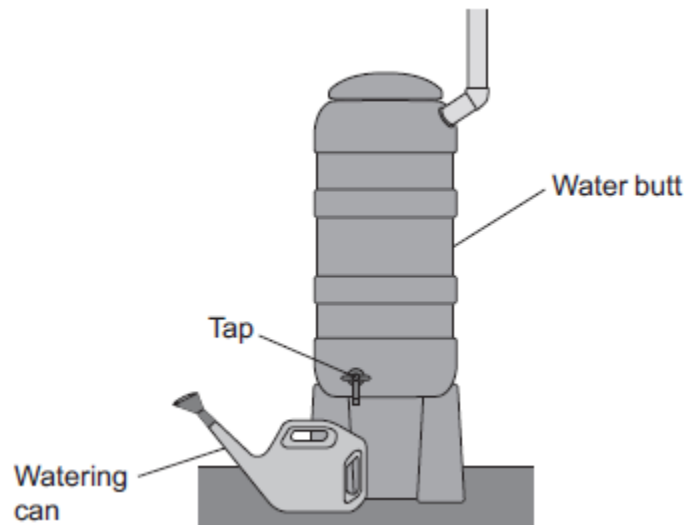

A tap allows water to be collected from the water butt in a watering can.

- (a) If the tap was placed higher up on the water butt, what difference would it make to the rate of flow of water from the tap?

Explain your answer.

---

---

---

---

(2)

- (b) A hosepipe is now attached to the tap. The hosepipe takes water to where it is needed.

A gardener did an investigation to see how the rate of flow of water through a hosepipe, from a water butt, varies with the length of the hosepipe.

His results are shown in below table.

Length of hosepipe in metres	Water collected in 10 seconds in cm <sup>3</sup>
2.0	500
3.0	500
4.0	500
5.0	500
10.0	250
15.0	170

- (i) What conclusions can you make based on the results in the table above?

---



---



---



---

(2)

- (ii) Suggest further readings that should be taken to improve the investigation.

Give reasons for your answers.

---



---



---



---



---



---



---



---

(4)

