

1)

(a) Explain in terms of forces what is meant by a *couple*.



In your answer, you should use appropriate technical terms, spelled correctly.

.....
.....
..... [1]

(b) (i) Define *moment of a force*.

.....
..... [1]

(ii) Fig. 6.1 shows three forces acting on a rod.

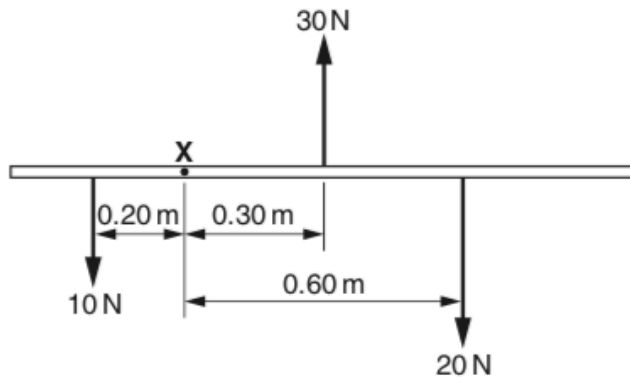

Fig. 6.1

By taking moments about point X, show that the rod is not in equilibrium when acted upon by these forces.

.....
..... [2]

[Total: 4]

2)

(a) Define *moment of a force*.



In your answer, you should use appropriate technical terms, spelled correctly.

.....
 [1]

(b) State the two conditions that apply when an object is in equilibrium.

1.
 2. [2]

(c) Fig. 4.1 is a diagram of a human arm lifting an object.

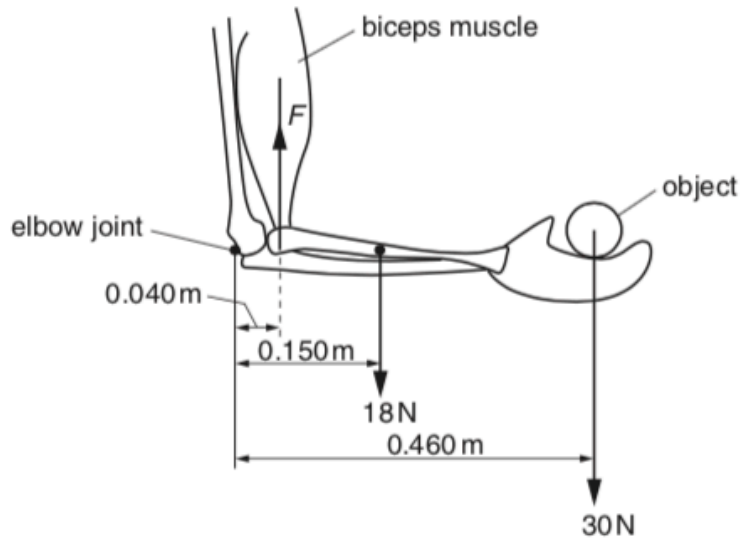

Fig. 4.1

The lower arm is horizontal and its centre of gravity is 0.150 m from the elbow joint. The weight of the lower arm is 18 N. The biceps muscle exerts a vertical force F on the arm. The horizontal distance between the elbow joint and the point of attachment of the muscle to the lower arm bone is 0.040 m. The weight of the object held in the hand is 30 N and its centre of gravity is 0.460 m from the elbow joint. The arm is in equilibrium.

(i) Define *centre of gravity*.

.....
 [1]

(ii) Calculate the total clockwise moment about the elbow joint.

total clockwise moment = Nm [2]

(iii) As the lower arm is moved away from the body, the force F exerted by the biceps muscles acts at an angle θ to the vertical as shown in Fig. 4.2.

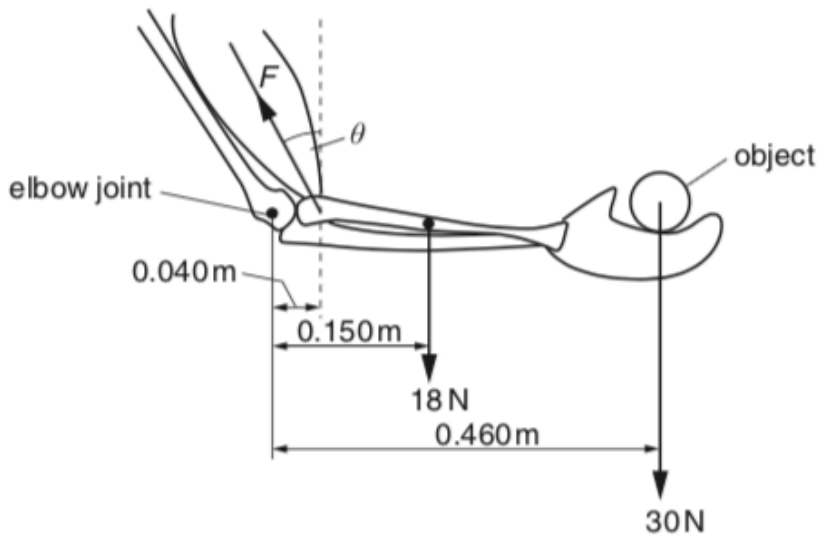

Fig. 4.2

The lower arm remains horizontal and in equilibrium. Describe and explain what happens to each of the following quantities as the angle θ is increased

1 the anticlockwise moment about the elbow joint

.....

2 the magnitude of the force F .

.....

 [3]

[Total: 9]

3)

(a) Define *torque of a couple*.

.....
 [1]

(b) Explain why *moment of a force* and *torque of a couple* have the same unit Nm.

.....
 [1]

(c) Fig. 4.1 shows an irregular shaped metal plate of constant thickness that can swing freely about point P.

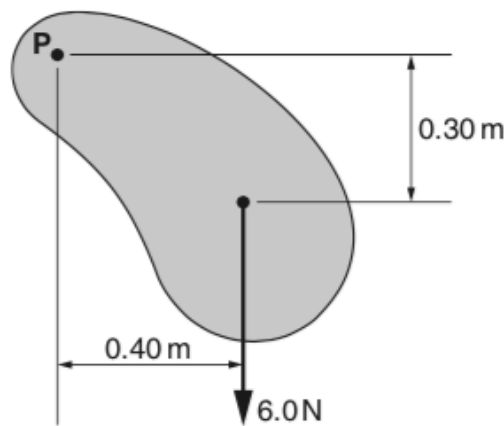

Fig. 4.1

(i) The weight of the plate is 6.0 N. With the plate in the position as shown in Fig. 4.1, calculate the clockwise moment of the weight of the plate about an axis through point P.

moment = Nm [1]

(ii) Explain why the moment of the weight reduces to zero when the plate reaches the bottom of the swing.

.....
 [1]

4)

(a) Fig. 7.1 shows several forces acting on an object that is free to move.

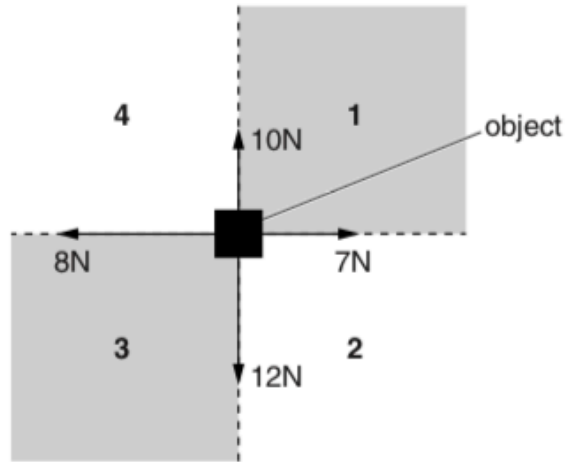

Fig. 7.1

Using simple calculations, deduce whether the object will move into region 1, 2, 3 or 4. Briefly explain your reasoning.

.....
.....
..... [2]

(b) State the *principle of moments*.

.....
.....
..... [1]

(c) Fig. 7.2 shows the forces acting on a suitcase with wheels as it is held stationary.

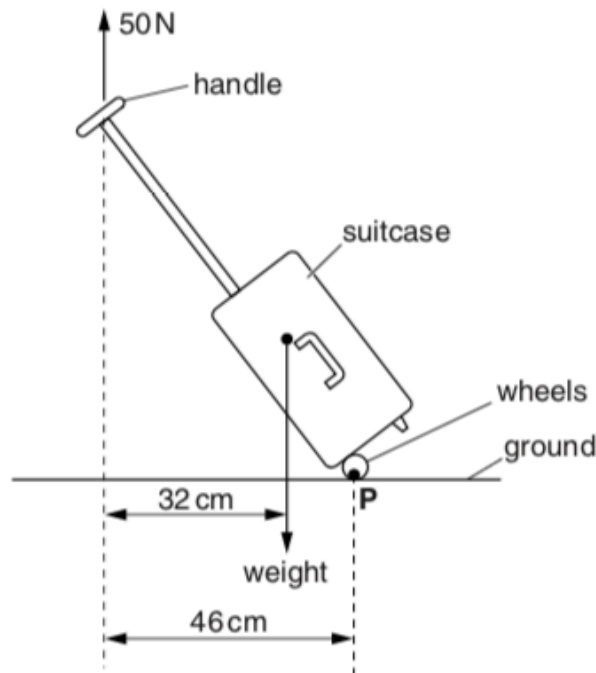

Fig. 7.2

A vertical force of 50 N is applied to the top of the handle in order to keep the suitcase stationary in the position shown in Fig. 7.2. The line of action of this force acts at a perpendicular distance of 46 cm from P, the point of contact with the ground. The line of action of the weight of the suitcase acts at a perpendicular distance of 32 cm from the top of the handle.

By taking moments about P, calculate the mass m of the suitcase.

$m = \dots\dots\dots$ kg [3]

[Total: 6]

5)

(a) Fig. 6.1 shows two equal but opposite forces acting on an object.

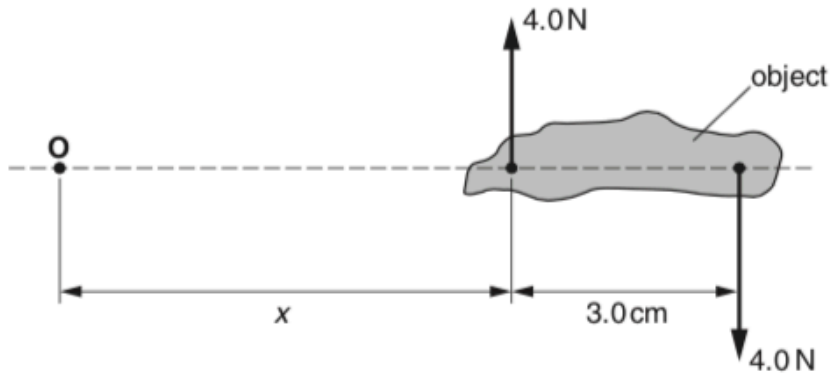

Fig. 6.1

The point **O** is at a distance x from the nearer of the two forces.

(i) The separation between the two parallel forces is 3.0 cm. Determine the torque of the couple exerted on the object.

torque = Nm [2]

(ii) Calculate the total moment of the forces about the point **O** and state the significance of this value.

.....
 [3]

(b) State two conditions necessary for an object to be in equilibrium.

.....

 [2]

(c) A concrete paving slab has mass 45 kg and dimensions 0.600 m × 0.600 m × 0.050 m.

(i) Calculate the density of the concrete.

density = kgm⁻³ [2]

(ii) Fig. 6.2 shows the concrete paving slab in equilibrium.

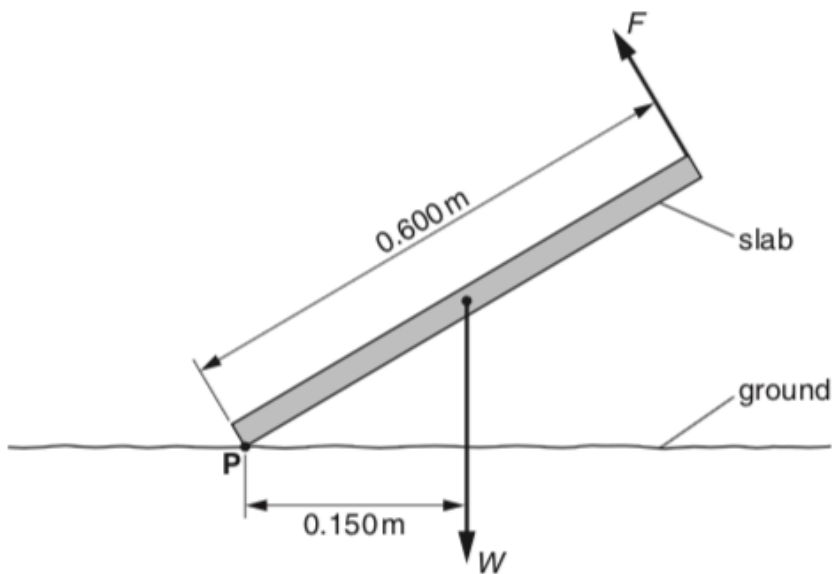

Fig. 6.2

Two forces acting on the slab are shown. The weight of the slab is W . The force F is applied at right angles to the end of the slab. By taking moments about P , determine the size of the force F .

$F = \dots\dots\dots$ N [3]

[Total: 12]

6)

(a) The areas under the graphs below are physical quantities.

(i) Fig. 1.1 shows a force against extension graph for a rubber band.

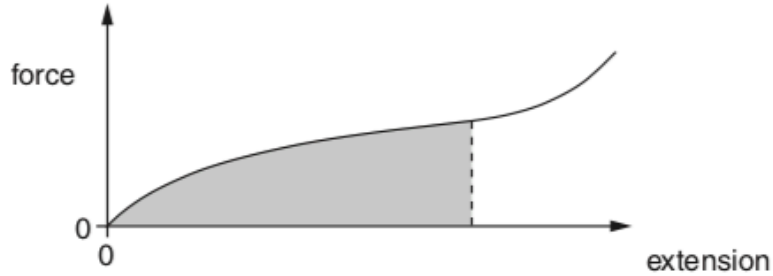

Fig. 1.1

State the quantity represented by the area under the force against extension graph.

..... [1]

(ii) Fig. 1.2 shows the velocity against time graph for an accelerating car.

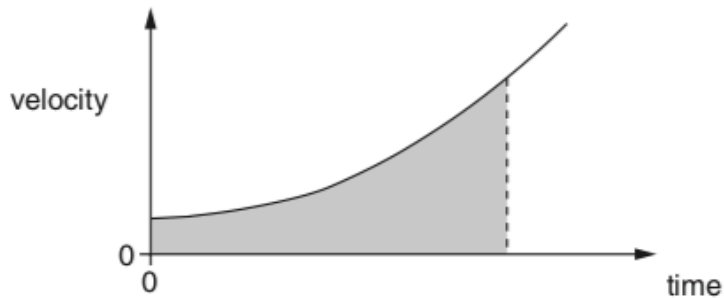

Fig. 1.2

State the quantity represented by the area under the velocity against time graph.

..... [1]

(b) State two quantities in physics that have the **same** unit of newton metre (Nm).

quantity 1 [1]

quantity 2 [1]

[Total: 4]

7)

(a) Define the following terms:

(i) *couple*

.....
..... [1]

(ii) *torque of a couple.*



In your answer, you should use appropriate technical terms, spelled correctly.

.....
..... [1]

(b) Fig. 4.1 shows a satellite in space moving from left to right.

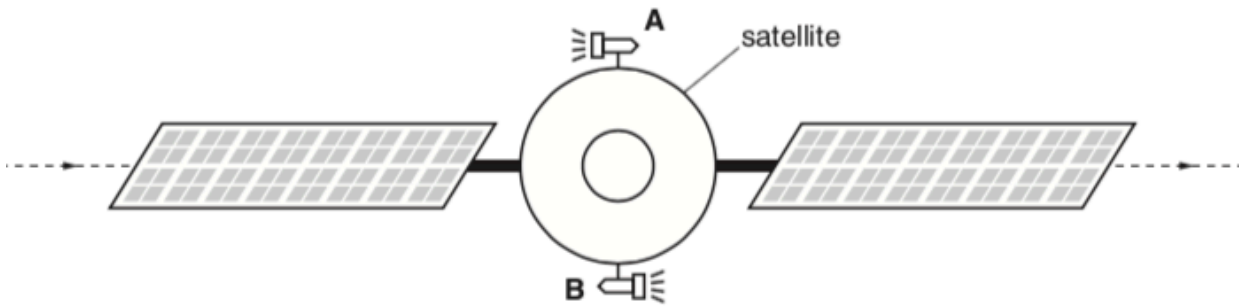

Fig. 4.1

The satellite has two small rockets **A** and **B** mounted at opposite ends of a diameter. When fired, each rocket motor provides the **same** constant force, but in **opposite** directions.

Describe the change in the motion of the satellite when

(i) both rocket motors are fired

.....
.....
..... [2]

(ii) only rocket motor **A** is fired.

.....
.....
..... [2]

[Total: 6]

8)

(a) Fig. 5.1 shows a wooden block motionless on an inclined ramp.

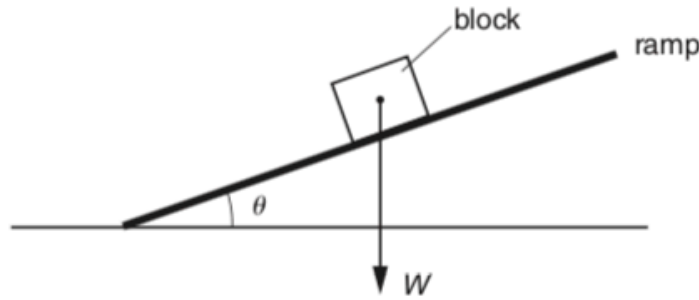

Fig. 5.1

The angle between the ramp and the horizontal is θ .

(i) The weight W of the block is already shown on Fig. 5.1. Complete the diagram by showing the normal contact (reaction) force N and the frictional force F acting on the block. [2]

(ii) Write an equation to show how F is related to W and θ .

.....
 [1]

(b) Fig. 5.2 shows a kitchen cupboard securely mounted to a vertical wall. The cupboard rests on a support at **A**.

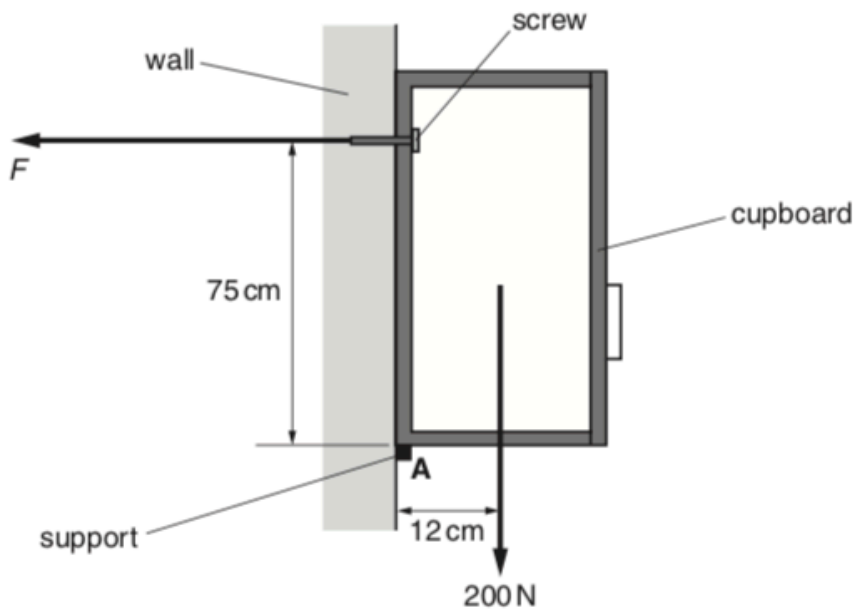

Fig. 5.2

The total weight of the cupboard and its contents is 200N. The line of action of its weight is at a distance of 12cm from **A**. The screw securing the cupboard to the wall is at a vertical distance of 75 cm from **A**.

- (i) State the principle of moments.



In your answer, you should use appropriate technical terms, spelled correctly.

.....
.....
..... [2]

- (ii) The direction of the force F provided by the screw on the cupboard is horizontal as shown in Fig. 5.2. Take moments about **A**. Determine the value of F .

$F = \dots\dots\dots$ N [2]

- (iii) The cross-sectional area under the head of the screw in contact with the cupboard is $6.0 \times 10^{-5} \text{m}^2$. Calculate the pressure on the cupboard under the screw head.

pressure = $\dots\dots\dots$ Pa [2]

- (iv) State and explain how your answer to (iii) would change, if at all, if the same screw was secured much closer to **A**.

.....
.....
..... [2]

[Total: 11]

9)

(a) State what is meant by the *centre of gravity* of an object.

.....
 [1]

(b) Define *moment of a force*.

.....
 [1]

(c) Fig. 5.1 shows a baby's mobile toy.

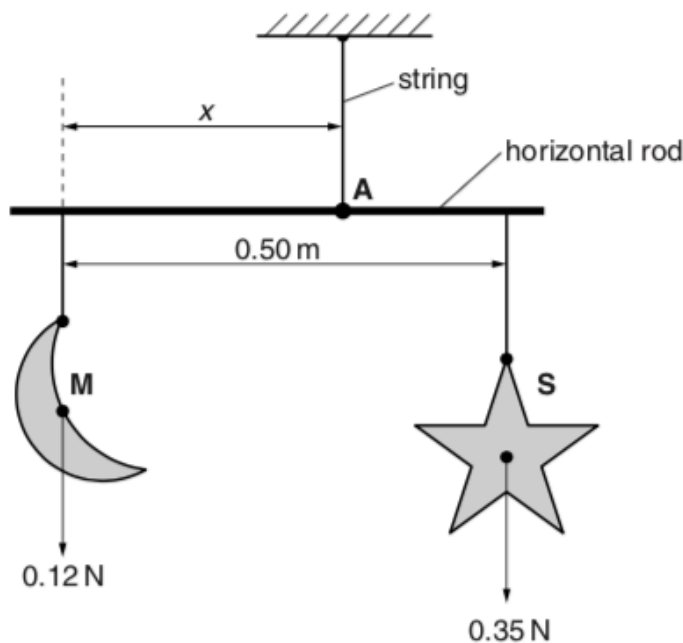

Fig. 5.1

The toy consists of a horizontal rod from which two objects shaped as a crescent moon **M** and a star **S** are suspended from lengths of string. The weight of the rod is negligible and it is pivoted about an axis passing through point **A** perpendicular to the plane of the diagram. The weights of **M** and **S** and the separation between the strings are shown in Fig. 5.1. The arrangement shown in Fig. 5.1 is in equilibrium.

(i) State **two** conditions necessary for the rod to be in equilibrium.

.....

 [2]

(ii) By taking moments about **A** determine the distance x .

$$x = \dots\dots\dots \text{ m [3]}$$

(iii) Determine the magnitude of the tension in the string attached to **A**.

$$\text{tension} = \dots\dots\dots \text{ N [1]}$$

[Total: 8]

10)

Fig. 2.1 shows an object held horizontally by a string.

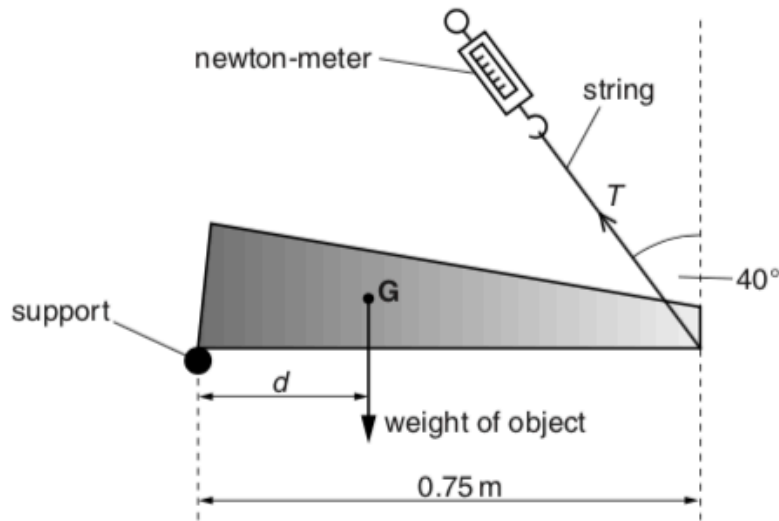

Fig. 2.1

One end of the object rests on a support and the other end is held by the string. The object is in equilibrium. Point **G** is the centre of gravity of the object. The mass of the object is 1.2 kg. The tension T in the string is 5.1 N. The string makes an angle of 40° with the vertical.

(a) Take moments about the support and calculate the distance d .

$d = \dots\dots\dots$ m [3]

(b) Explain why the force at the support cannot be vertically upwards.

.....

.....

.....

..... [1]

[Total: 4]

11)

(a) A block of concrete rests on the ground, as shown in Fig. 7.1.

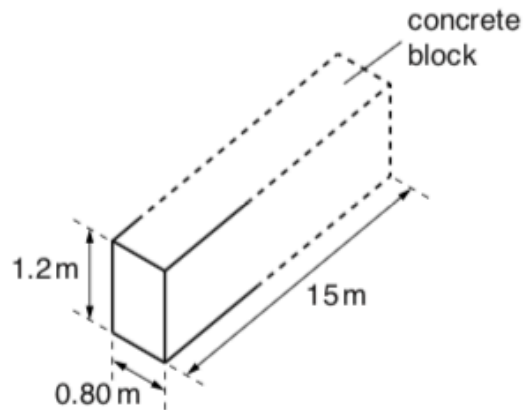

Fig. 7.1

The concrete block is 15m long, 0.80m wide and 1.2m high. The density of concrete is $2.4 \times 10^3 \text{ kg m}^{-3}$. Calculate

(i) the weight of the concrete

weight = N [2]

(ii) the pressure exerted on the ground by the block of concrete.

pressure = Pa [2]

(b) Fig. 7.2 shows two vertical walls supporting a uniform horizontal platform in equilibrium.

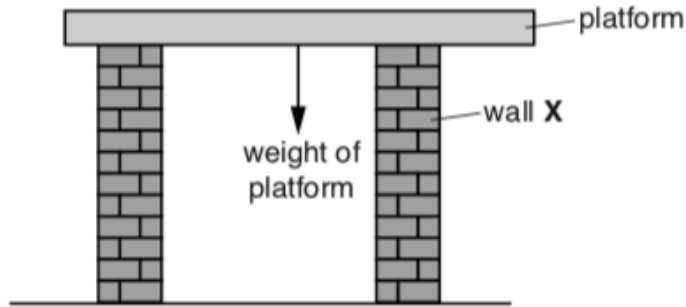

Fig. 7.2

(i) The net force acting on the platform is zero. State another condition that applies to this platform.

.....
..... [1]

(ii) The walls exert upward forces on the platform. An engineer suggests that the wall X should be moved a little further away from the centre of gravity of the platform and the opposite wall left where it is.

State and explain the effect this change would have on the force exerted by wall X on the platform.

.....
.....
.....
.....
..... [2]

12)

Fig. 4.1 shows a cyclist.

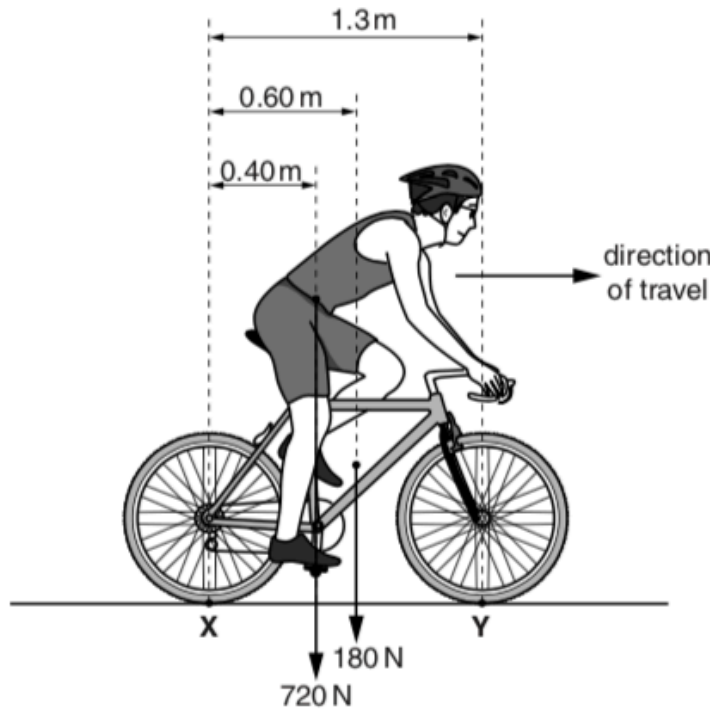

Fig. 4.1

The bicycle tyres are in contact with the road at **X** and **Y**. The cyclist is travelling at **constant** velocity on a level road. The weight of the bicycle is 180N and the weight of the cyclist is 720N.

(a) State the magnitude of the resultant force acting on the cyclist. Explain your answer.

.....

 [2]

(b) Define *moment of a force*.



In your answer, you should use appropriate technical terms, spelled correctly.

.....

 [1]

(c) Explain why the two vertical forces acting on the tyres at **X** and **Y** do not form a couple.

.....

 [1]

(d) Take moments about **X** to determine the size of the vertical force F acting **on** the tyre at **Y**.

$F = \dots\dots\dots$ N [3]

(e) The cyclist leans further forward. How does this affect the force on the tyre at **X**? Explain your answer.

.....
.....
.....
.....
..... [2]